



Parts Manual

Mfg. No: 7800982B-00
P2185020E, 21" 8.5 TP Steel Deck
Electric Start Series 20

7061201 - 21" Recycling Steel Deck Plug Kit.
7061200 - 21" Recycling Steel Deck Cover Kit.

Not For
Reproduction

Model Components	Page
Bag, Discharge & Mulch Group.....	4
Decals Group.....	6
Drive System.....	8
Electric Start Group.....	12
Engine, Deck & Blade Group, 21PE.....	14
Handles & Controls.....	16
Transmission Assembly.....	18
Wheel & Height-of-Cut Group.....	20
Torque Specification Chart.....	22

Not For
Reproduction

Bag, Discharge & Mulch Group

Note: Unless noted otherwise, use the standard torque specifications

Mfg. No: 7800982B-00

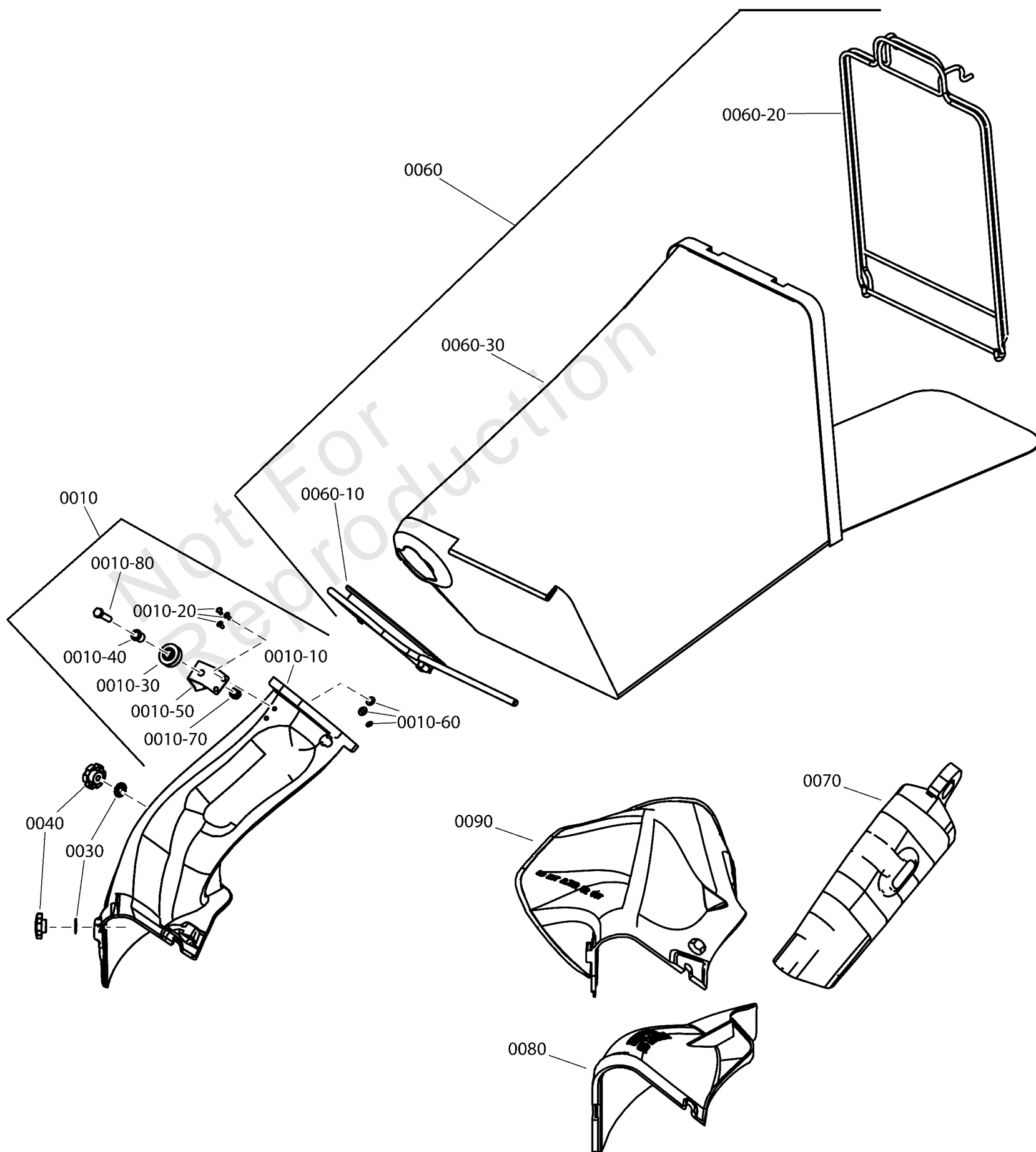

Bag, Discharge & Mulch Group

REF NO	PART NO	QTY	DESCRIPTION
0010	7600117YP	1	BAG ADAPTER ASSY. KIT
0010-10	-----	1	USE 7600117, Bag Adapter
0010-20	704032	3	RIVET, 3/16X.344
0010-30	7024228SM	1	PULLEY, Nylon, .75 ID, 1.3 OD
0010-40	703973	1	BUSHING
0010-50	7047082AYP	1	BRACKET, Rope Pulley
0010-60	703942	3	WASHER, 5/32 Flat, ZC/CL
0010-70	703409	1	NUT, 5/16-18, GR5
0010-80	703570	1	CAPSCREW, Hex Head, 5/16-18 x 1 1/4
0030	703936	2	WASHER, .325IDX.850OD
0040	7101022YP	2	KNOB, Fluted (5/16-18 thread) on side chute
0060	7500153YP	1	ASSEMBLY, Grass Bag, Door, No Graphics, 12.5" W, 26.5" L
0060-10	7042489AYP	1	WELDMENT, Bag Connector
0060-20	7051906AYP	1	ASSEMBLY, Bag Wire, 12.25" Wide
0060-30	7100433YP	1	GRASS BAG, Door, No Graphics, 12.5" W, 26.5" L
0070	7016814YP	1	PLUG, Chute Adapter Mulching
0080	7029149YP	1	COVER, Mulching, 21" Deck
0090	7042965YP	1	CHUTE, 21" Side Discharge

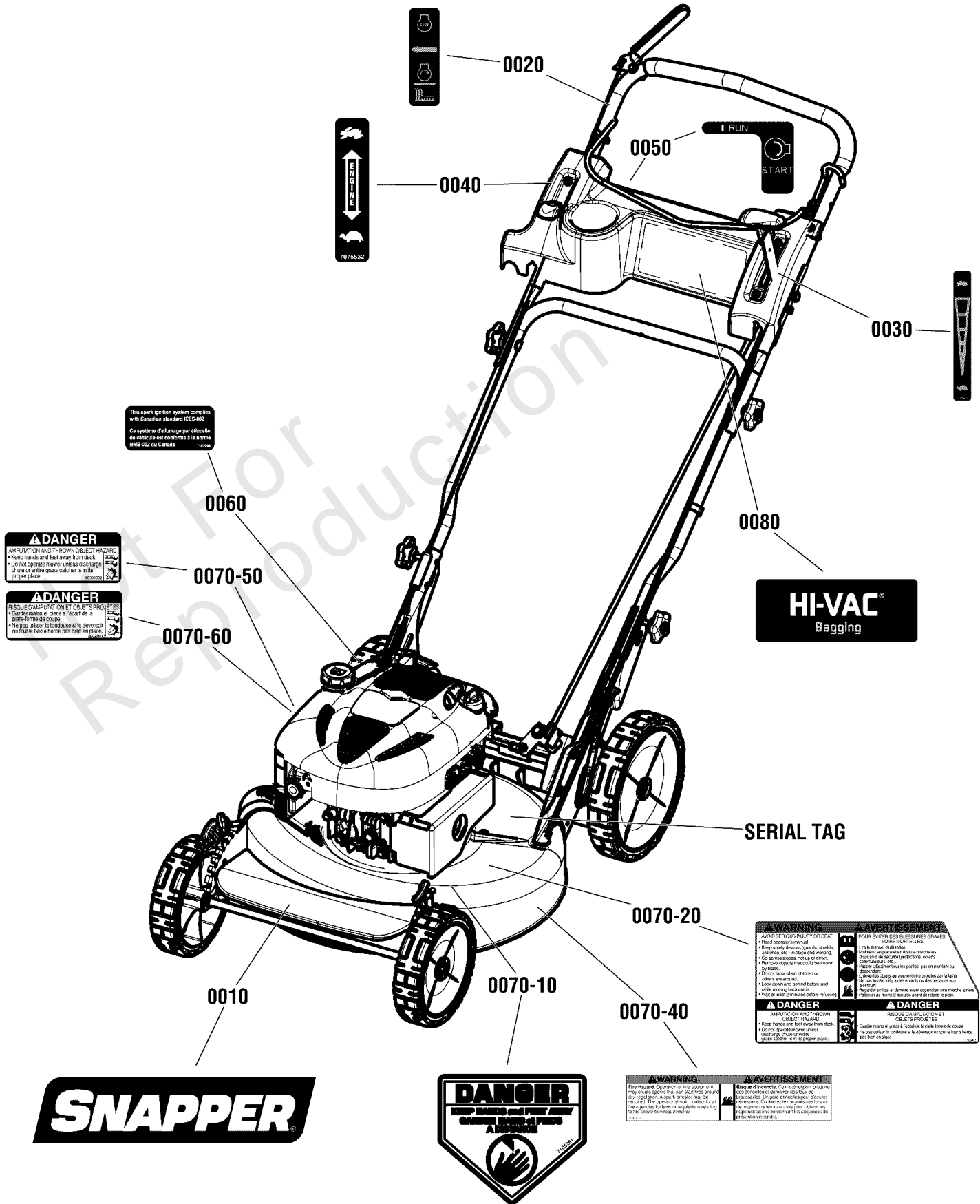

Decals Group

REF NO	PART NO	QTY	DESCRIPTION
0010	7104148YP	1	DECAL, LOGO, REAR
0020	7029782MA	1	DECAL, OPC Bail International Symbol
0030	7075471YP	1	DECAL, Speed Shift
0040	7075532YP	1	DECAL, Throttle Control, B&S
0050	7075688YP	1	DECAL, Ignition Switch
0060	7102996YP	1	DECAL, ICES, Canadian Spark Compliance
0070	7106353YP	1	DECAL SHEET, WARNINGS
0070-10	7105261YP	1	DECAL, CPSC, Cut Finger, French/English -(Included on Decal Sheet #7106353YP)
0070-20	-----	1	DECAL, Warning/Danger, ENG/FRENCH -(Included on Decal Sheet #7106353YP)
0070-40	-----	1	DECAL, Spark Arrestor, ENG/FRENCH -(Included on Decal Sheet #7106353YP)
0070-50	84002306	1	DECAL, Danger, English -(Included on Decal Sheet #7106353YP)
0070-60	80018999	1	DECAL, Danger, French -(Included on Decal Sheet #7106353YP)
0080	7106322YP	1	DECAL, HI-VAC, Bagging -(Included on Decal Sheet #7106353YP)

Drive System

Note: Unless noted otherwise, use the standard torque specifications

Mfg. No: 7800982B-00

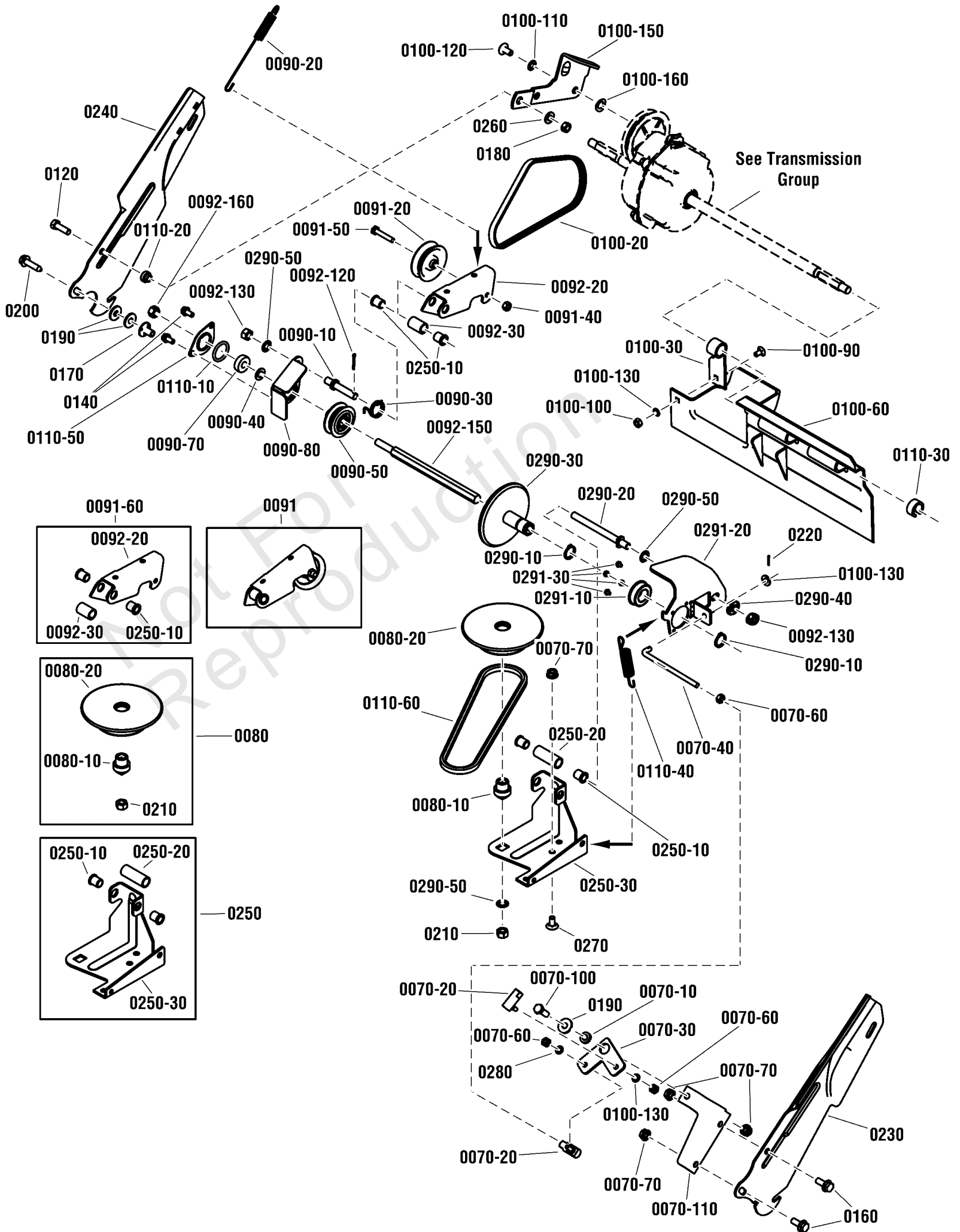

Drive System

REF NO	PART NO	QTY	DESCRIPTION
0110-10	704008	1	O-RING, 1IDX1.25X.125
0110-20	7012114SM	1	BUSHING, Differential Link
0110-30	704009	1	RING, .68IDX.93X.44
0110-40	7029025YP	1	SPRING, Extension, .58 x 3.2
0110-50	7031809YP	1	HOLDER, Bearing (Outer Half), ZC/CL
0110-60	7046784YP	1	BELT, Engine Drive (Stretch)
0070-10	703970	1	SPACER
0070-20	7015753YP	2	BALL JOINT, 1/4-28
0070-30	7073913YP	1	BELL CRANK, Black Zinc
0070-40	7074145YP	1	LINK, Transfer (1/4-28 thread)
0070-60	703461	3	NUT, 1/4-28 Hex, GR5, Zinc/Clear
0070-70	703409	4	NUT, 5/16-18, GR5
0070-100	703408	1	CAPSCREW, 5/16-18
0070-110	7073822BMYP	1	BRACKET, Bell Crank
0080	7061275YP	1	KIT, Drive Disc, Steel (includes Disc, Bushing & Nut)
0080-10	703971	1	BUSHING
0080-20	7073528YP	1	DRIVE DISC, Steel (Includes Bushing)
0090-10	703836	1	STUD, 3/8-24X2.380
0090-20	7012122YP	1	SPRING, Clutch, Adjustable Tension
0090-30	7012126YP	1	SPRING, Idler Torsion
0090-40	703946	1	WASHER, .39IDX.72OD
0090-50	7019383YP	1	PULLEY, Poly-V, 2" OD, .65" Wide, Steel
0090-70	7028014YP	1	BALL BEARING, Spherical O.D., .38 I.D.
0090-80	7031873YP	1	HOLDER, Bearing (Inner Half)
0091	7051921YP	1	ASSEMBLY, Clutch Idler (Pulley, Nut, Bolt, Bushings & Spacer)
0091-20	7012124YP	1	PULLEY, Flat Idler, .25 ID, 2.25 OD
0091-40	703972	1	NUT, HEX TOP, 1/4-28
0091-50	703828	1	CAPSCREW, 1/4-28X1.75
0091-60	7600173YP	1	KIT, Idler Arm, Bushing & Spacer Assembly
0092-20	7032832AYP	1	ARM, CLUTCH IDLER
0092-30	703974	1	SPACER, Idler Arm (.500 ID x .970 Long), ZC/CL
0092-120	703312	1	PIN, COTTER, 3/32X.75
0092-130	703895	2	NUT, HEX, 3/8-24
0092-150	7072284YP	1	SHAFT, Hex (3/8-24 thread, one end)
0092-160	703458	1	NUT, HEX, 3/8-24
0100-20	7012354YP	1	BELT, Poly-V, Kevlar, V21
0100-30	7012616YP	1	SUPPORT, Foot Guard
0100-60	7029008YP	1	GUARD, Foot, P21 EURO, Long
0100-90	703978	1	BOLT, 1/4-20X0.5
0100-100	703127	1	NUT
0100-110	703587	1	WASHER, 5/16
0100-120	1753983YP	1	SCREW, Truss Head
0100-130	703462	3	WASHER, LOCK, 1/4
0100-150	7034179BMYP	1	LINK, DIFFERENTIAL
0100-160	703940	1	WASHER, .445IDX.78OD
0120	703301	1	BOLT, HEX, 5/16-24X1
0140	704130	2	SCREW, HEX, 1/4-20X.5
0160	703354	2	SCREW, 5/16-18
0170	703947	1	NUT, 5/16-18 X .625, Weld, ZC/CL
0180	703896	1	NUT, HEX, 5/16-24
0190	703118	3	WASHER, Flat, 7/8, GR5

Drive System

Note: Unless noted otherwise, use the standard torque specifications

Mfg. No: 7800982B-00

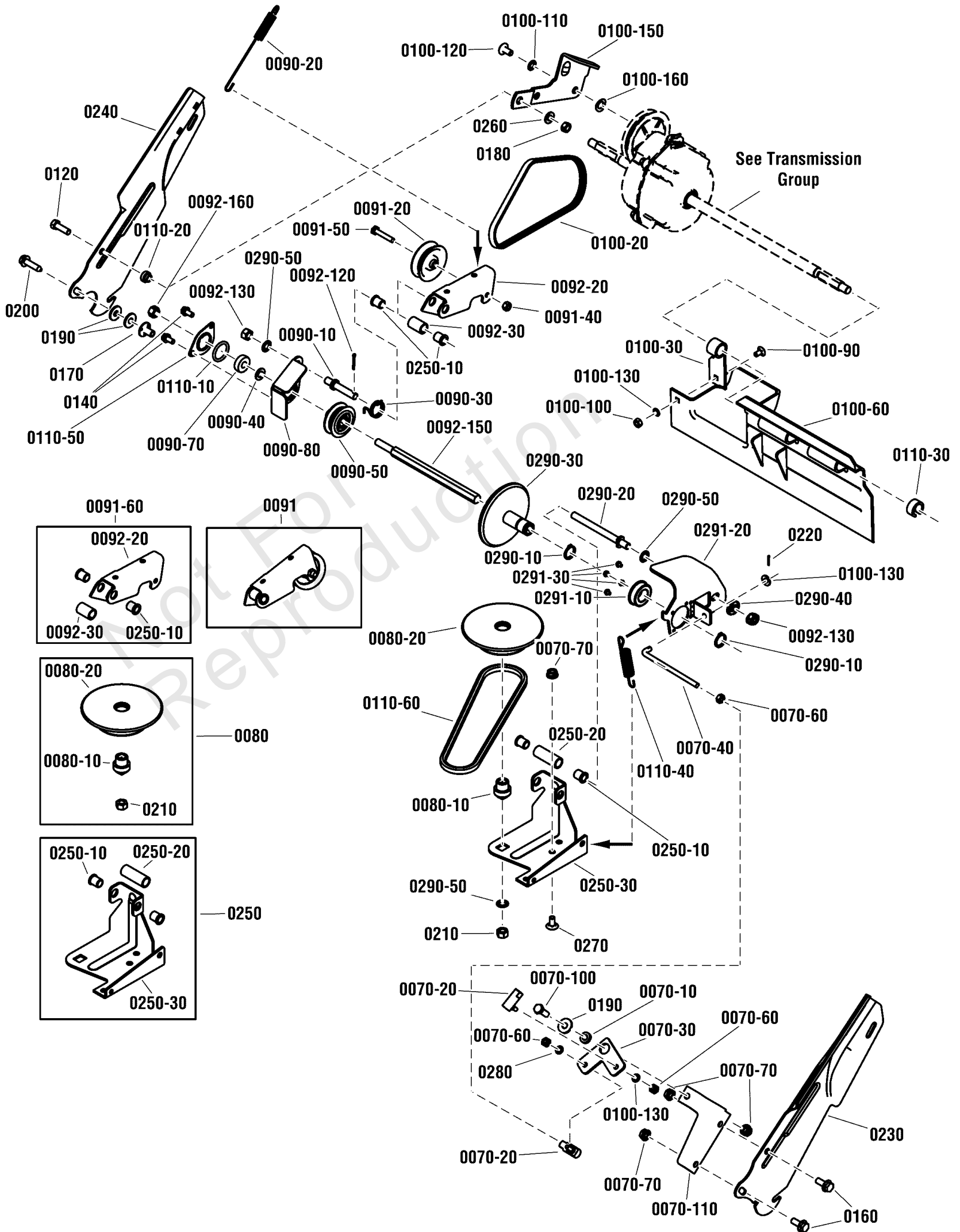

Drive System

REF NO	PART NO	QTY	DESCRIPTION
0200	703167	1	SCREW
0210	703457	1	NUT, HEX,3/8-16, GR5
0220	703464	1	PIN, COTTER, 1/16X0.5
0230	7033985AYP	1	HANDLE, Lower, ADJ, LH
0240	7033986AYP	1	HANDLE, LOWER, RH
0250	7052987BMYP	1	ASSEMBLY, Deck Bracket, P21S
0250-10	703973	4	BUSHING
0250-20	703941	1	SPACER, .5IDX.64OD
0250-30	7033774YP	1	BRKT, DECK, P21S
0260	703350	1	WASHER
0270	703447	1	BOLT, 5/16-18X.625 G5
0280	703332	1	WASHER
0290-10	703975	2	RETAINER, RING, 3/4
0290-20	703837	1	STUD, 3/8-24X4.5
0290-30	7041855YP	1	DRIVEN DISC, Cantilever
0290-40	703590	1	WASHER, FLAT, .406
0290-50	703930	3	WASHER, INT LCK, 3/8
0291-10	7029027YP	1	BEARING, 3/4" ID, Ball, Commercial
0291-20	7300977AYP	1	THRUST PLATE, Short, Black
0291-30	704061	4	SCREW,HEX, #10-32X.25

Electric Start Group

Note: Unless noted otherwise, use the standard torque specifications

Mfg. No: 7800982B-00

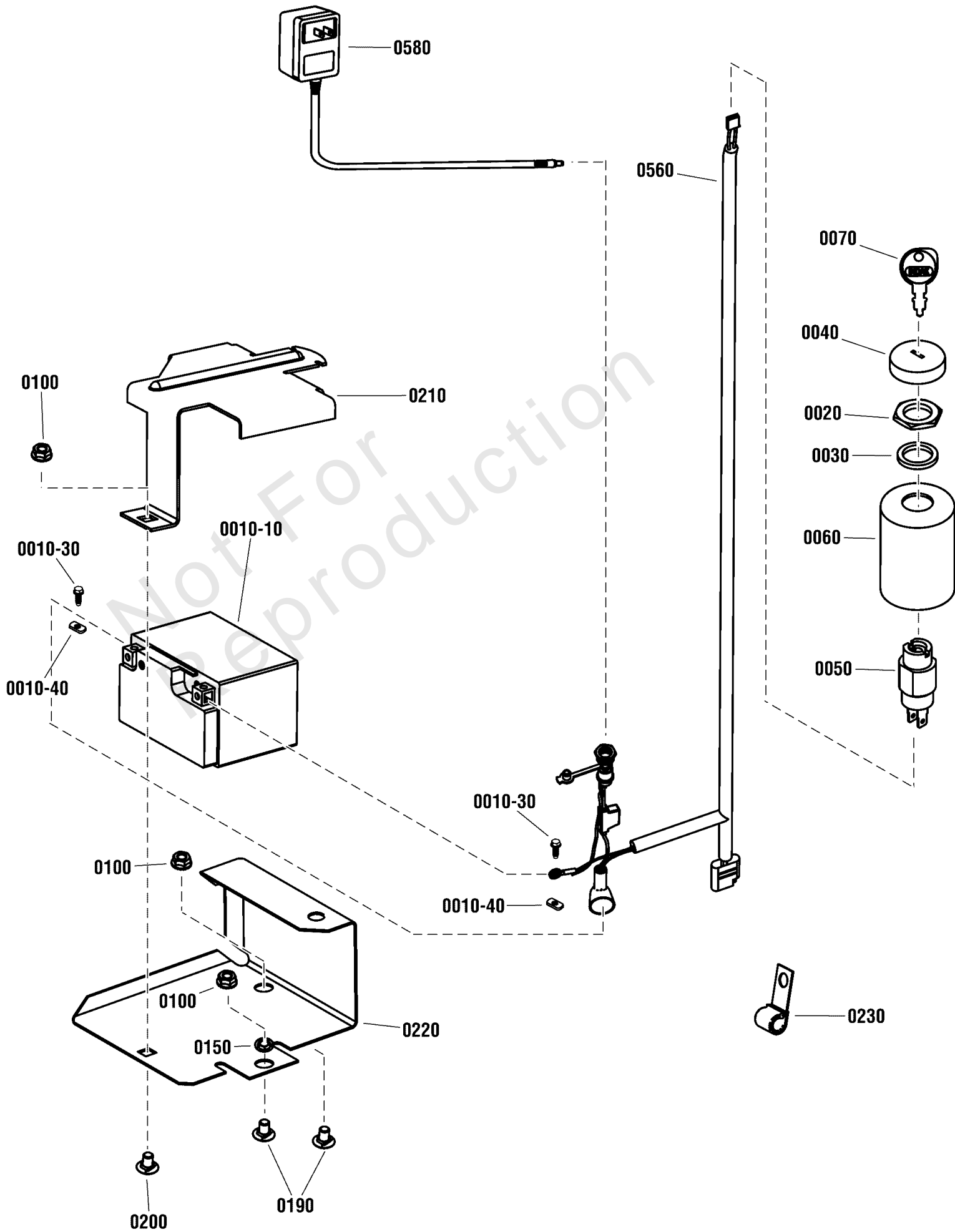

Electric Start Group

REF NO	PART NO	QTY	DESCRIPTION
0010-10	7600224YP	1	KIT, Battery, 12 V, 4.0AH, (includes Acid, Hardware & Instr.)
0010-30	7043977YP	2	SCREW, #10-24 x 1/2 Pan Head Machine
0010-40	7090932	2	NUT, #10-24 Square
0020	704229	1	NUT, 5/8-32, Hex, ZC/CL
0030	7016132SM	1	SPACER, .875 OD X.654 ID X.104 L ZN
0040	7023506SM	1	BEZEL
0050	690646	1	SWITCH, Key
0060	7029080YP	1	COVER, Key Switch
0070	7011138YP	1	KEY, Ignition, Pair
0100	703409	3	NUT, 5/16-18, GR5
0150	703297	1	RETAINER, GR5, 5/16
0190	703447	1	BOLT, 5/16-18X.625 G5
0200	703798	2	BOLT, 5/16-18X0.50
0210	7036132AYP	1	COVER, Battery
0220	7106294BMYP	1	BRACKET, Battery, W/Charge Port
0230	7012652YP	1	CLIP, Wire, 7/16
0560	7106273YP	1	WIRING HARNESS, W/Coax Jack, B&S WBM
0580	705927	1	CHARGER, 120VAC, 12VDC Output, .75A, 2.5mm Round Plug

Engine, Deck & Blade Group, 21PE

Note: Unless noted otherwise, use the standard torque specifications

Mfg. No: 7800982B-00

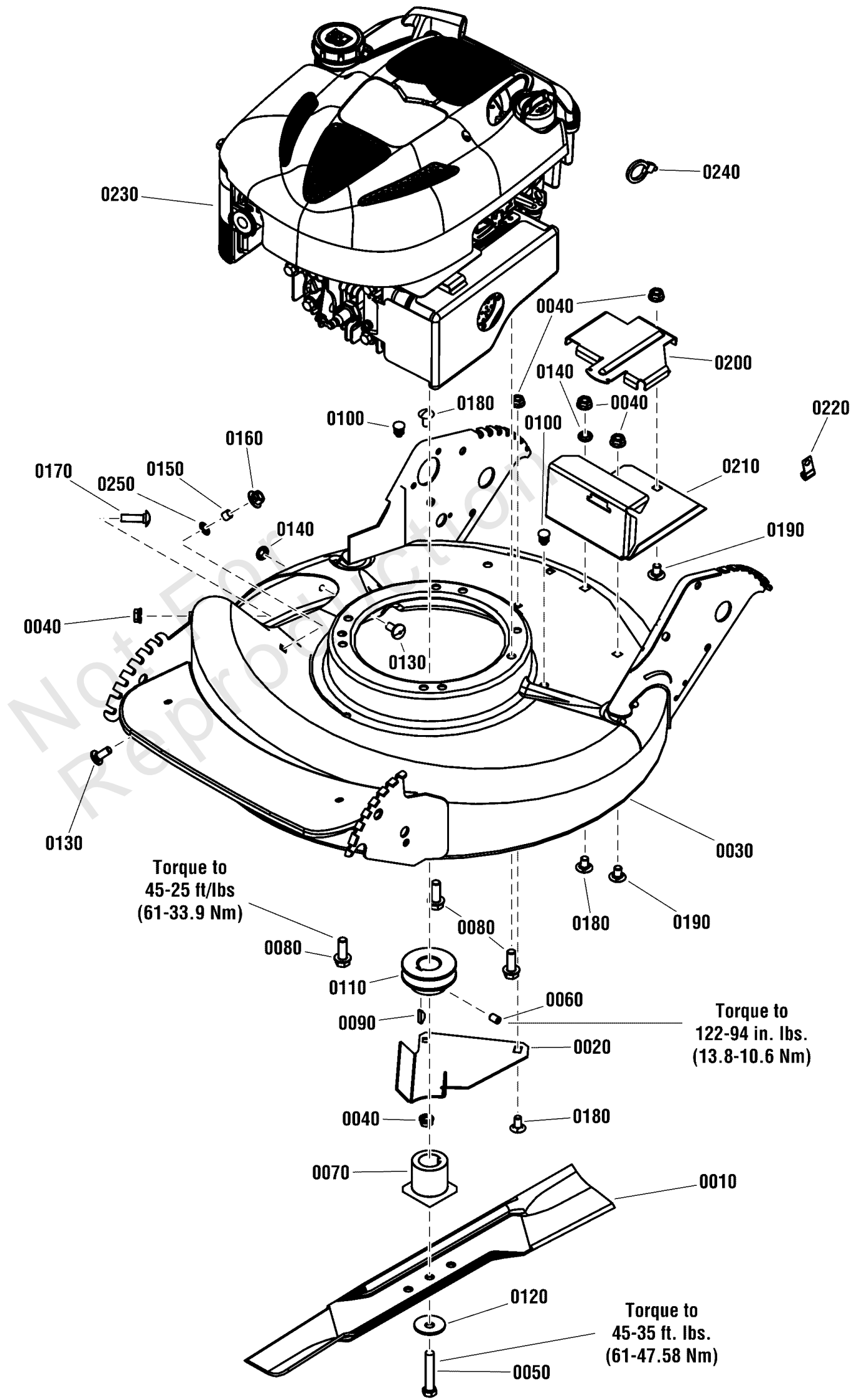

Engine, Deck & Blade Group, 21PE

REF NO	PART NO	QTY	DESCRIPTION
0010	7026691BZYP	1	BLADE, 21" STD.LIFT
0020	7074568YP	1	COVER, Belt, Zinc/Clear
0030	7500549DYP	1	DECK KIT, HI-VAC
0040	703409	6	NUT, 5/16-18, GR5
0050	703999	1	SCREW, 3/8-24 x 2" Hex Head Cap, GR 5
0060	704003	1	SET SCREW, 5/16-18 x 1/2" Hex Recess
0070	7015626YP	1	HUB, Blade Drive, .25MM ID
0080	704000	3	SCREW, Hex Washer Head, Taptite, 3/8-16 x 1
0090	703891	1	KEY, 3/16X.625
0100	7046780SM	2	PLUG, Hole, .44" OD
0110	7105122YP	1	PULLEY, Engine (25mm I. D. x 2-1/8 O.D.)
0120	703963	1	WASHER, CONE
0130	703185	2	BOLT, Round Head, Short Square Neck
0140	703297	3	RETAINER, GR5, 5/16
0150	7024340SM	2	SPACER
0160	704001	1	NUT, 5/16-18
0170	704002	1	BOLT,5/16-18X1.125
0180	703447	3	BOLT, 5/16-18X.625 G5
0190	703798	2	BOLT, 5/16-18X0.50
0200	7036132AYP	1	COVER, Battery
0210	7106294BMYP	1	BRACKET, Battery, W/Charge Port
0220	7012652YP	2	CLIP, Wire, 7/16
0230	123P05-0064-F1	2	* ENGINE, B&S 8.5 GT, PRO, ES, Model #123P05-0064-F1
0240	703586	2	TIE, SELF LOCKING

Footnotes:

NOTE: * Purchase parts from your B&S engine distributor.

Handles & Controls

Note: Unless noted otherwise, use the standard torque specifications

Mfg. No: 7800982B-00

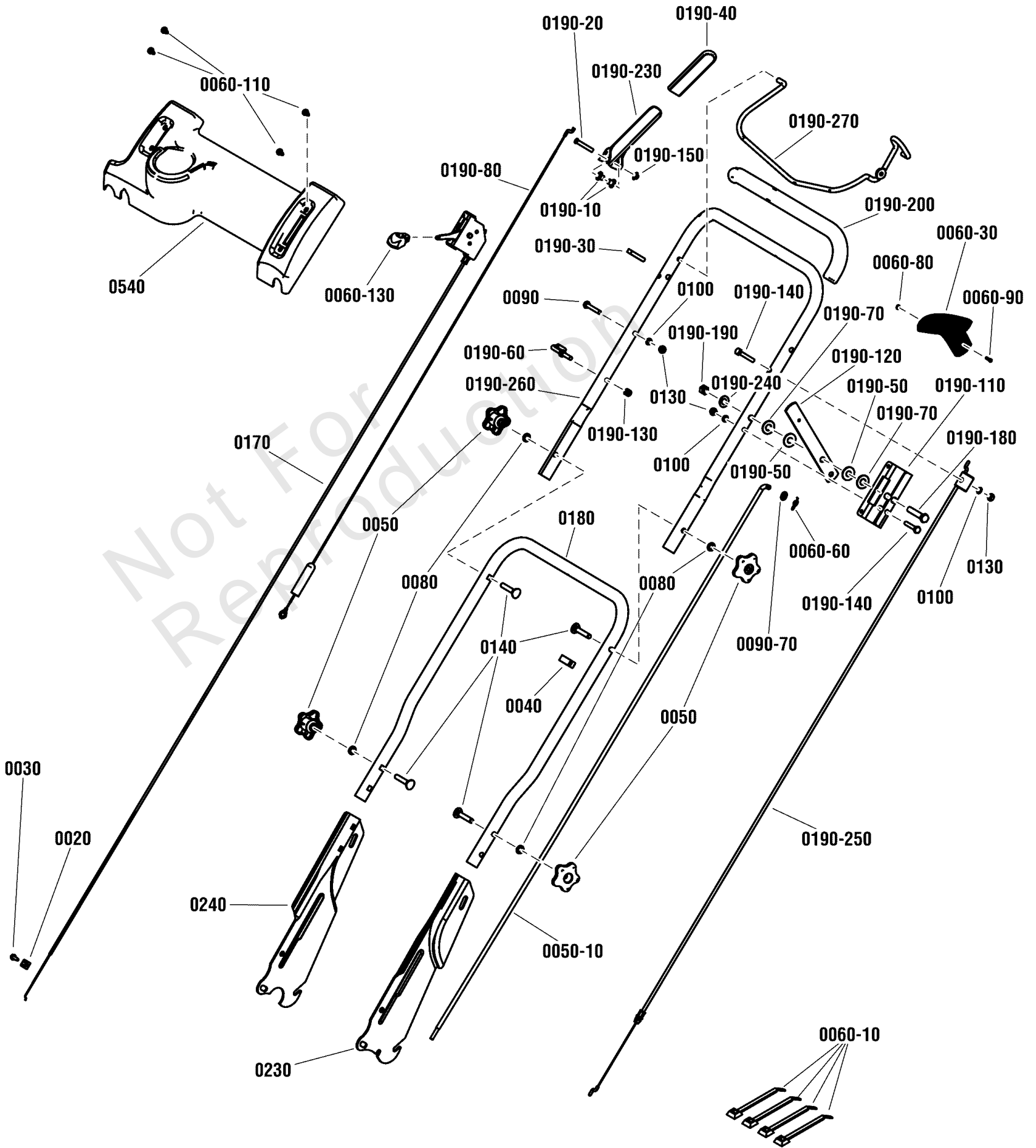

Handles & Controls

REF NO	PART NO	QTY	DESCRIPTION
0020	690798	1	CLAMP, Casing
0030	704324	1	SCREW, #10-32 X .615, Hex Head Cap Slotted, Zinc/Clear
0040	7023813SM	1	CLIP, Wiring Harness
0050	7105085YP	4	KNOB,HANDLE,5 PRONG
0050-10	7074133YP	1	ROD, Speed Control (35.5" L, 1/4-28 thread)
0060-10	7024641YP	5	WIRE TIE, 5.5" L
0060-20	704030	1	PIN,COTTER,5/16X1.044
0060-30	7075182YP	1	KNOB, Shift, Red
0060-60	703350	1	WASHER
0060-80	703460	1	NUT, Hex #8-32
0060-90	703351	1	SCREW, #8-32 X 0.50, Machine Fillister Head, Zinc/Clear
0060-110	703961	4	SCREW, 1/4-20 x .550 Pan Head Torx, Self-Tap
0060-130	7075308YP	1	KNOB, Throttle, Red
0080	703587	4	WASHER, 5/16
0090	703588	1	SCREW
0100	703462	3	WASHER, LOCK, 1/4
0130	703127	3	NUT
0140	703059	4	BOLT, 5/16-18X2
0170	84002242	1	CONTROL, Throttle, W14
0180	7106232AYP	1	HANDLE, Middle, Black
0190-10	7014343YP	2	BUSHING, Flange .27 ID x .35 x .4, Nylon, Black
0190-20	704031	1	PIN, CLEVIS, 1/4X1.5
0190-30	7026219YP	1	CLAMP, 7/8" Double Cable
0190-40	7028407YP	1	GRIP, International Symbol, 4.6" Black
0190-50	704004	2	WASHER,.406IDX1OD
0190-60	7028488MA	1	GUIDE, 1/4-20, Rope, CL/ZC
0190-70	703964	2	WASHER, FLAT
0190-80	7034604YP	1	CABLE, Clutch Control, 41.25" L
0190-110	7074003YP	1	BRACKET, Shift, Black Zinc
0190-120	7074113BMYP	1	LEVER, Shift, Black
0190-130	703232	1	NUT, 1/4-20, NYLOCK
0190-140	703234	2	CAPSCREW, 1/4-20X1.5
0190-150	704005	1	PUSHNUT, CAP, 1/4
0190-180	703589	1	CAPSCREW, 3/8-16X2
0190-190	703347	1	NUT, 3/8-16
0190-200	7023810	1	FOAM GRIP, 18.75" long
0190-230	7074473BMYP	1	HANDLE, CLUTCH
0190-240	704006	1	WASHER, .393IDX.760OD
0190-250	7106257YP	1	CABLE, OPC, 50.56" Long, Z Ends, Snap-in, for Over-the-Top Bail
0190-260	7106258AYP	1	HANDLE
0190-270	7106255AYP	1	BAIL, OPC, Control, Over The Top, Black
0230	7033985AYP	1	HANDLE, Lower, ADJ, LH
0240	7033986AYP	1	HANDLE, LOWER, RH
0540	7106282YP	1	PANEL, Dash, Propelled, W/Throttle

Transmission Assembly

Note: Unless noted otherwise, use the standard torque specifications

Mfg. No: 7800982B-00

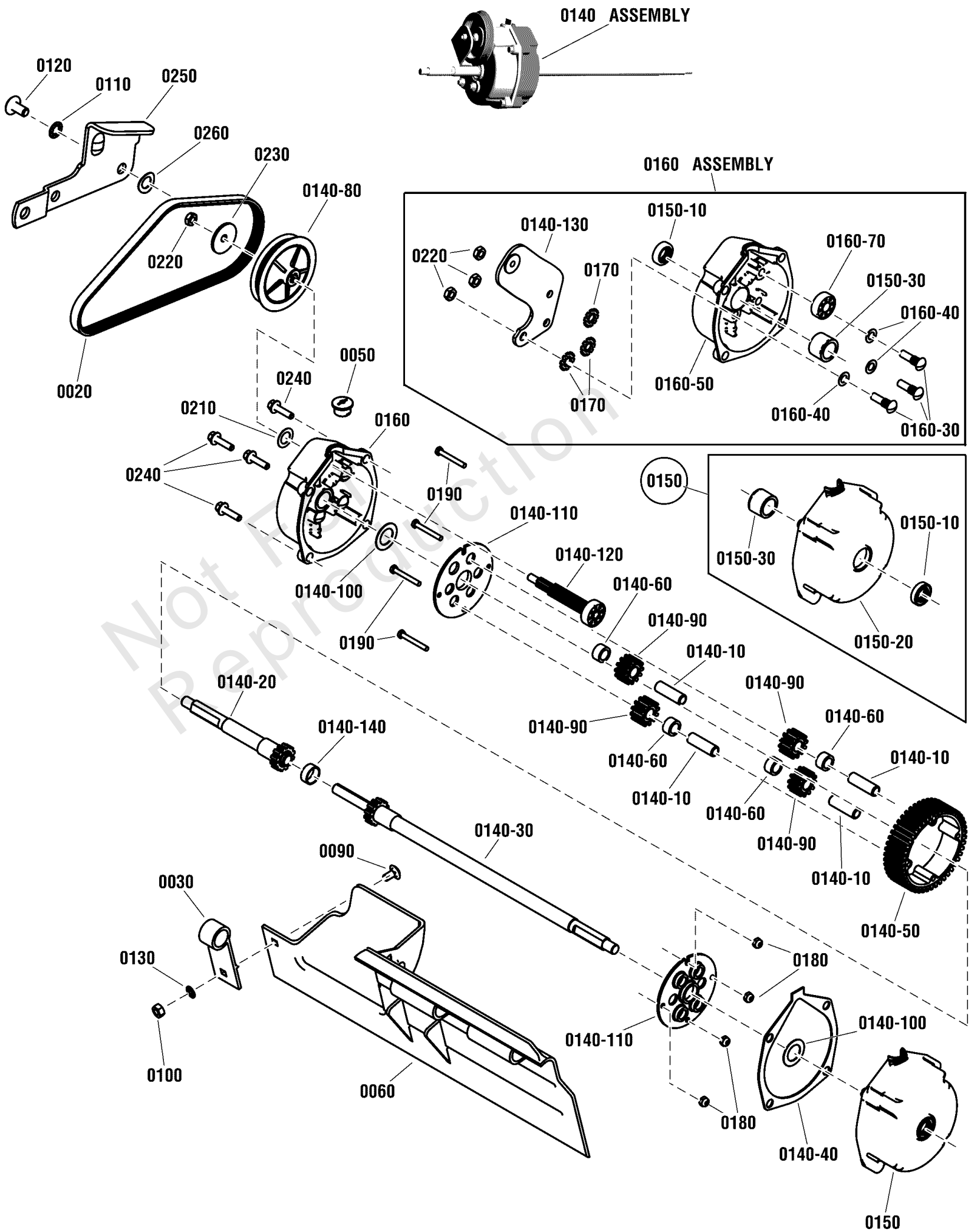

Transmission Assembly

REF NO	PART NO	QTY	DESCRIPTION
0020	7012354YP	1	BELT, Poly-V, V21
0030	7012616YP	1	SUPPORT, Foot Guard
0040	-----		GREASE, Darina 00 (Not Shown, Use 4oz. Max)
0050	703931	1	PLUG, TRANSMISSION
0060	7029008YP	1	GUARD, Foot
0090	703978	1	BOLT, 1/4-20X0.5
0100	703127	1	NUT
0110	7090391SM	1	WASHER, 5/16, Internal Lock, Zinc/Clear
0120	1753983YP	1	SCREW, 5/16-18 x 5/8 Truss Head Torx
0130	703462	1	WASHER, LOCK, 1/4
0140	7053943YP	1	ASSEMBLY, Transmission, 21P
0140-10	7011110YP	4	SHAFT, Pinion, .471 OD, 1.5" Long
0140-40	7011774YP	1	GASKET, V21
0140-50	7012495YP	1	GEAR, 46T, V21
0140-60	703933	4	SPACER, .48IDX.70OD
0140-80	7019213YP	1	PULLEY, Poly-V (3.5 O.D.)
0140-90	7021115YP	4	GEAR, Pinion (12 Tooth, .625 Thick)
0140-100	7031965YP	2	WASHER, 1.25 X .765 X .03, Thrust, ZC/CL
0140-110	7031970YP	2	PLATE, Differential Gear, V21
0140-120	7050767YP	1	ASSEMBLY, Input Gear
0140-130	7051903AYP	1	WELDMENT, Differential Bracket
0140-140	703934	1	SPACER, .72IDX.82OD
0140-20	7050830YP	1	ASSEMBLY, Short Axle
0140-30	7050831YP	1	ASSEMBLY, Long Axle
0150	7053939YP	1	ASSEMBLY, Left Housing
0150-10	7012314YP	2	SEAL, 5/8" ID
0150-20	7029033YP	1	HOUSING, Left Hand
0150-30	7029035YP	2	BEARING, Tapered, Differential Housing
0160	7051908YP	1	ASSEMBLY, Housing, Right Hand
0160-30	703935	3	BOLT, 5/16-24X1.125
0160-40	7024442YP	3	GASKET, 5/8" O.D.
0160-50	7029034YP	1	HOUSING, Right Hand
0160-70	7073963YP	1	BEARING, Ball, 1.125 OD, .440 ID, 3.8 Wide
0170	703936	3	WASHER, .325IDX.850OD
0180	703937	4	NUT, NYLOCK, 10-32
0190	703938	4	CAPSCREW, 10-32X1.5
0210	703349	1	WSHR, 0.453
0220	703459	4	NUT, HEX, 5/16-24
0230	703939	1	WASHER, .32IDX1.4OD
0240	703833	4	SCREW, 1/4-20 x 1 Hex Washer Self-Tap, ZC/CL
0250	7034179BMYP	1	LINK, DIFFERENTIAL
0260	703940	1	WASHER, .445IDX.78OD

Wheel & Height-of-Cut Group

Note: Unless noted otherwise, use the standard torque specifications

Mfg. No: 7800982B-00

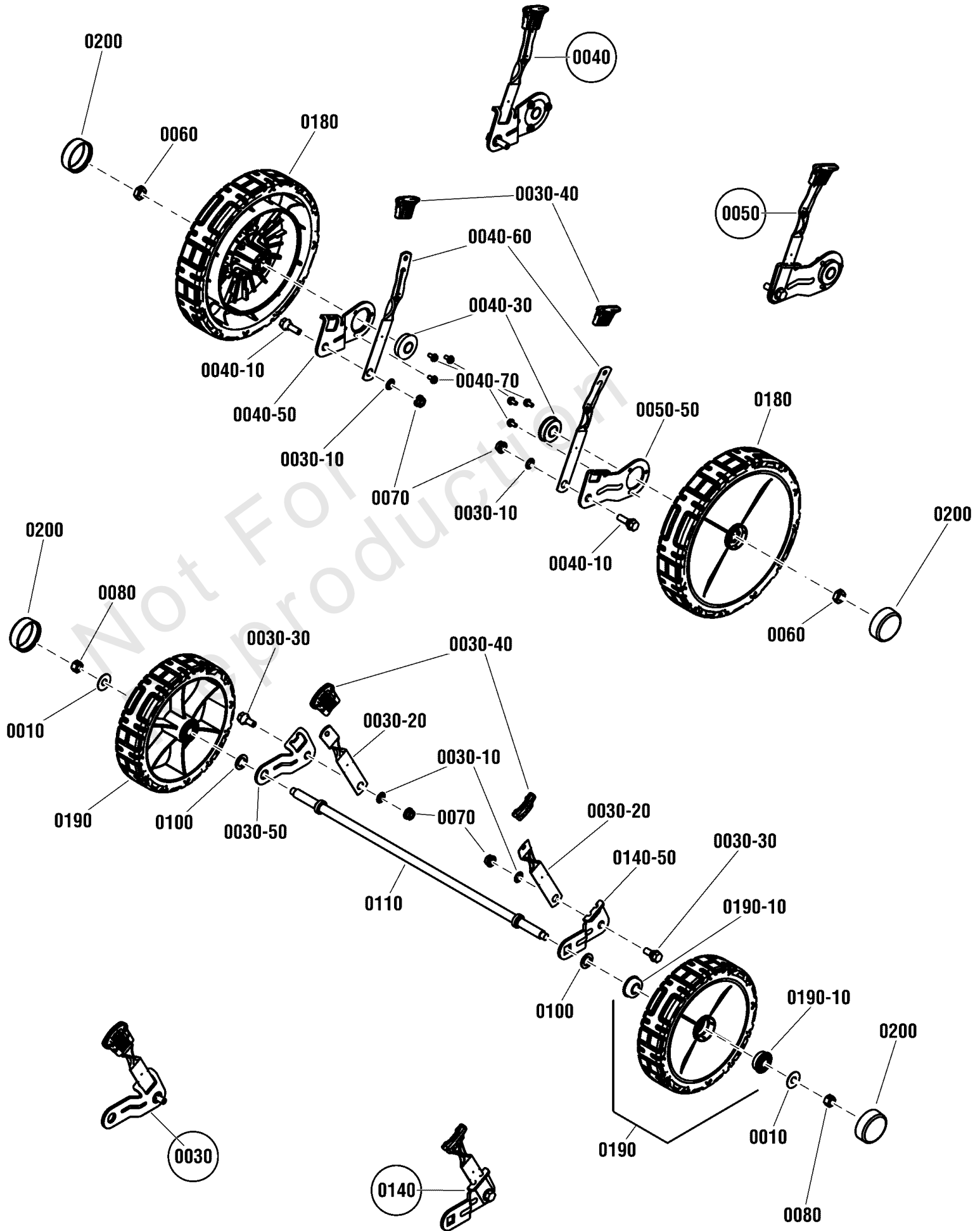

Wheel & Height-of-Cut Group

REF NO	PART NO	QTY	DESCRIPTION
0010	703966	2	WASHER, FLAT, .377X1
0030	7600180YP	1	KIT, FRONT WHEEL ARM
0030-10	703297	4	RETAINER, GR5, 5/16
0030-20	7012325YP	2	LATCH, Height
0030-30	703839	2	BOLT, 5/16-18X.75
0030-40	7103793YP	4	GRIP, HT LATCH, BLACK
0030-50	7031017YP	1	WHEEL ARM, Front, Round Hole, RH, Clear
0040	7054246YP	1	WHEEL ARM ASMY, RR
0040-10	703840	2	BOLT,SHLDR 5/16-18X1
0040-30	7012312YP	2	BEARING, 9/16" ID
0040-50	7032722YP	1	WHEEL ARM, REAR RH
0040-60	7035717YP	2	LATCH, Height Adjusting, (long)
0040-70	703967	6	SCREW, #10-32X0.375
0050	7054247YP	1	WHEEL ARM ASMY, LR
0050-50	7032723YP	1	ARM, Wheel, Left Rear, Zinc/Clear
0050	7054247YP	1	WHEEL ARM ASMY, LR
0060	770537	2	NUT, 7/16-20, Hex Flanged Center Lock, ZC/CL
0070	703409	4	NUT, 5/16-18, GR5
0080	703347	2	NUT, 3/8-16
0100	703835	2	WASHER, .531IDX.875OD
0110	7100752YP	1	AXLE, Easy Line (20.44" L, 3/8-16 Threads)
0140	7600183YP	1	KIT, FRONT WHEEL ARM
0140-50	7011393YP	1	WHEEL ARM, L.H. Front (.512 Square Hole) CZ/CL
0180	7503280YP	2	ASSEMBLY, Wheel, 10"X2" DD" Insert Drive, Cool Gray
0190	7503282YP	2	ASSEMBLY, Wheel, 8 X 2 Idle w/Bearings, Gray
0190-10	7101380YP	4	BALL BEARING, 1-1/8 O.D., Flange
0200	7106302YP	4	HUBCAP, Round, 1.7" OD, Gray

Hardware Identification & Torque Specifications

Torque Specification Chart								
FOR STANDARD METRIC MACHINE HARDWARE (Tolerance ± 20%)								
Property Class	5.6		8.8		10.9		12.9	
	Class 5.6		Class 8.8		Class 10.9		Class 12.9	
Size Of Hardware	in/lbs	Nm.	in/lbs	Nm.	in/lbs	Nm.	in/lbs	Nm.
	ft/lbs		ft/lbs		ft/lbs		ft/lbs	
M3	5.88	.56	13.44	1.28	19.2	1.80	22.92	2.15
M4	13.44	1.28	30.72	2.90	43.44	4.10	52.56	4.95
M5	26.4	2.50	60.96	5.75	5.97	8.10	7.15	9.7
M6	44.64	4.3	7.3	9.9	10.3	14	12.1	16.5
M7	5.2	7.1	12.1	16.5	16.9	23	19.9	27
M8	7.7	10.5	17.7	24	25	34	29	40
M10	15	21	35	48	50	67	59	81
M12	26	36	61	83	86.2	117	103	140
M14	42	58	101	132	136	185	162	220
M16	64	88	147	200	210	285	250	340
M18	89	121	202	275	287	390	346	470
M20	126	171	290	390	405	550	486	660
M22	169	230	390	530	559	745	656	890
M24	217	295	497	375	708	960	840	1140
M27	320	435	733	995	1032	1400	1239	1680
M30	435	590	995	1350	1401	1900	1681	2280
M33	590	800	1349	1830	1902	2580	2278	3090
M36	759	1030	1740	2360	2441	3310	2935	3980
M39	988	1340	2249	3050	3163	4290	3798	5150

Torque Specification Chart						
FOR STANDARD MACHINE HARDWARE (Tolerance ± 20%)						
Hardware Grade	No Marks		SAE Grade 5		SAE Grade 8	
	SAE Grade 2		SAE Grade 5		SAE Grade 8	
Size Of Hardware	in/lbs	Nm.	in/lbs	Nm.	in/lbs	Nm.
	ft/lbs		ft/lbs		ft/lbs	
8-32	19	2.1	30	3.4	41	4.6
8-36	20	2.3	31	3.5	43	4.9
10-24	27	3.1	43	4.9	60	6.8
10-32	31	3.5	49	5.5	68	7.7
1/4-20	66	7.6	8	10.9	12	16.3
1/4-28	76	8.6	10	13.6	14	19.0
5/16-18	11	15.0	17	23.1	25	34.0
5/16-24	12	16.3	19	25.8	29	34.0
3/8-16	20	27.2	30	40.8	45	61.2
3/8-24	23	31.3	35	47.6	50	68.0
7/16-14	30	40.8	50	68.0	70	95.2
7/16-20	35	47.6	55	74.8	80	108.8
1/2-13	50	68.0	75	102.0	110	149.6
1/2-20	55	74.8	90	122.4	120	163.2
9/16-12	65	88.4	110	149.6	150	204.0
9/16-18	75	102.0	120	163.2	170	231.2
5/8-11	90	122.4	150	204.0	220	299.2
5/8-18	100	136	180	244.8	240	326.4
3/4-10	160	217.6	260	353.6	386	525.0
3/4-16	180	244.8	300	408.0	420	571.2
7/8-9	140	190.4	400	544.0	600	816.0
7/8-14	155	210.8	440	598.4	660	897.6
1-8	220	299.2	580	788.8	900	1,244.0
1-12	240	326.4	640	870.4	1,000	1,360.0

The guides and ruler furnished below are designed to help you select the appropriate hardware.

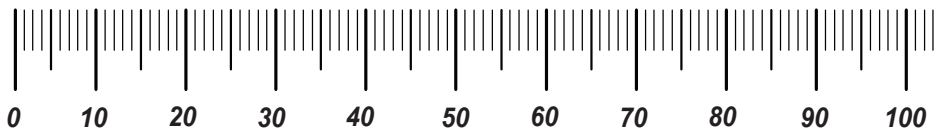

Nut, M8

Thread Diameter (mm)

Inside Diameter (in) Threads per inch

Nut, 1/2-16



Screw, M8- 1.25 x 25

Thread Diameter (mm) Distance between threads (mm) Body Length (mm)

Body Diameter Threads per inch Body Length (in)

Screw, 1/2- 16 x 2



Standard Hardware Sizing

When a washer or nut is identified as 1/2" (M8), this is the *Nominal size*, meaning the *inside diameter* is 1/2 inch (8mm metric thread diameter); if a second number is present it represents the *threads per inch* (distance between threads).

When bolt or capscrew is identified as 1/2 - 16 x 2" (M8 - 1.25 x 50), this means the *Nominal size*, or body diameter is 1/2 inch (8mm metric thread diameter), the second number, 16, represents the *threads per inch*, (*distance between threads*). The final number is the body length of the bolt or screw, 2 inches (50mm).

NOTES

- These torque values are to be used for all hardware excluding: locknuts, self-tapping screws, thread forming screws, sheet metal screws and socket head setscrews.
- Recommended seating torque values for locknuts:
 - for prevailing torque locknuts - use 65% of grade 5 torques.
 - for flange whizlock nuts and screws - use 135% of grade 5 torques.
- Unless otherwise noted on assembly drawings, all torque values must meet this specification.

Common Hardware Types

Hex Head Capscrew



Washer



Carriage Bolt



Hex Nut

Wrench & Fastener Size Guide

1/4" Bolt or Nut Wrench—7/16"	5/16" Bolt or Nut Wrench—1/2"	3/8" Bolt or Nut Wrench—9/16"	7/16" Bolt or Nut Wrench (Bolt)—5/8" Wrench (Nut)—11/16"	1/2" Bolt or Nut Wrench—3/4"
M6 Bolt or Nut Wrench—10mm	M8 Bolt or Nut Wrench—13mm	M10 Bolt or Nut Wrench—17mm	M12 Bolt or Nut Wrench—19mm	M14 Bolt or Nut Wrench—22mm

