



Parts Manual

Mfg. No: 7800968B-00
CRP218520, 21" 8.5 GTP Steel Deck
Commercial Series 20

7060935YP - 21" Grass Catcher Kit.....
7060936YP - 21" Grass Catcher Kit.....

Not For
Reproduction

Model Components	Page
Decal Group.....	4
Deck, Engine & Blade Group.....	6
Drive System, Self Propelled.....	8
Handle Group.....	12
Transmission Assembly.....	14
Wheels, Brackets & Latches.....	16
Torque Specification Chart.....	18

Not For
Reproduction

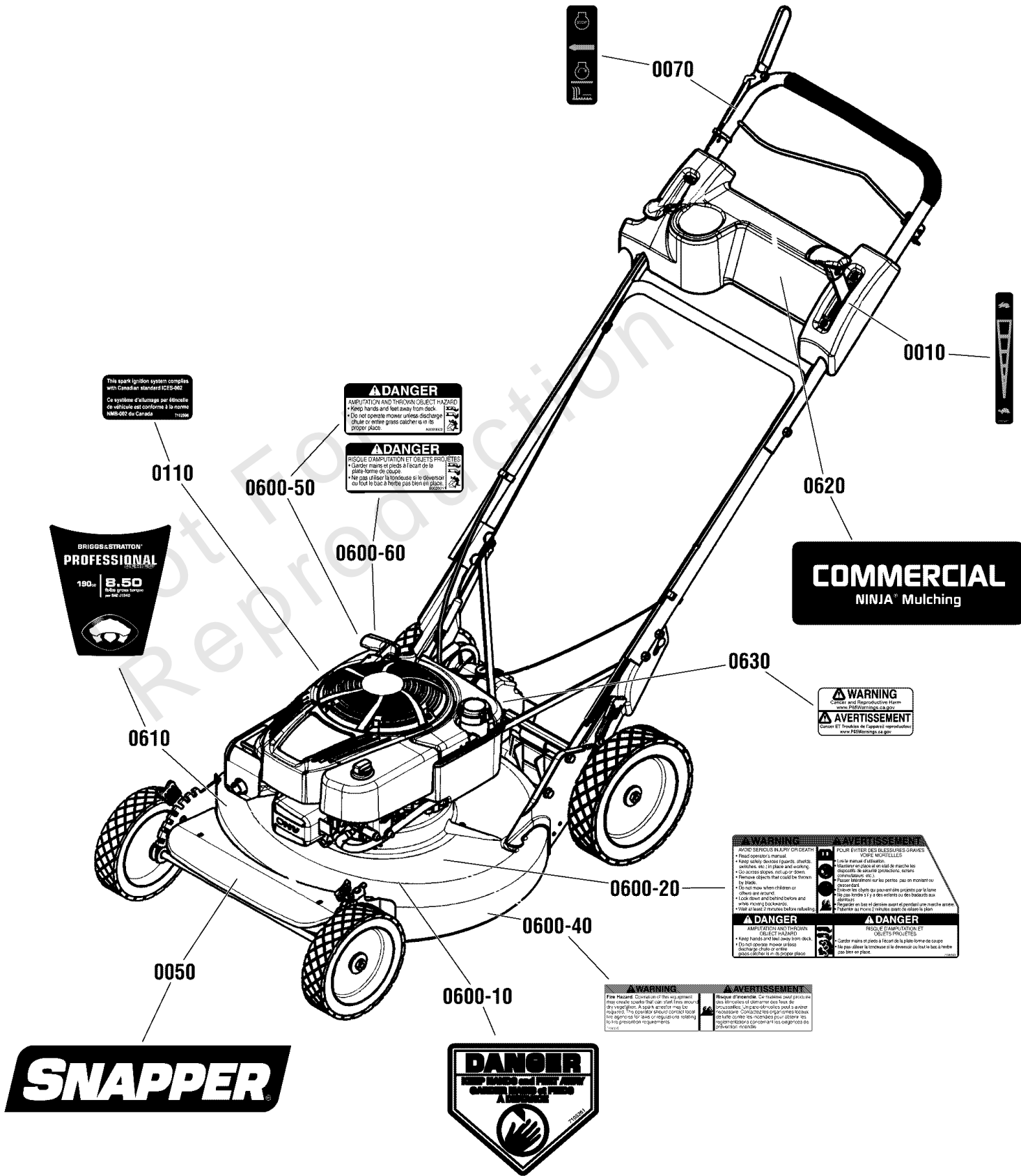

Decal Group

REF NO	PART NO	QTY	DESCRIPTION
0010	7075471YP	1	DECAL, Speed Shift
0050	7104148YP	1	DECAL, LOGO, REAR
0070	7029782MA	1	DECAL, OPC Bail International Symbol
0110	7102996YP	1	DECAL, ICES, Canadian Spark Compliance
0600	7106353	1	SHEET, DECAL, WBM COMPLIANCE
0600-10	7105261YP	1	DECAL, CPSC, French/English
0600-20	-----	1	DECAL, Warning/Danger, English/French -(Included on Decal Sheet #7106353YP)
0600-40	-----	1	DECAL, Spark Arrestor, English/French -(Included on Decal Sheet #7106353YP)
0600-50	-----	1	DECAL, Danger, English -(Included on Decal Sheet #7106353YP)
0600-60	-----	1	DECAL, Danger, French -(Included on Decal Sheet #7106353YP)
0610	7106320YP	1	DECAL, Turtle, 8.50TP
0620	7106324YP	1	DECAL, Commercial Ninja
0630	84002303	1	LABEL, WARNING

Not For Reproduction

Deck, Engine & Blade Group

Note: Unless noted otherwise, use the standard torque specifications

Mfg. No: 7800968B-00

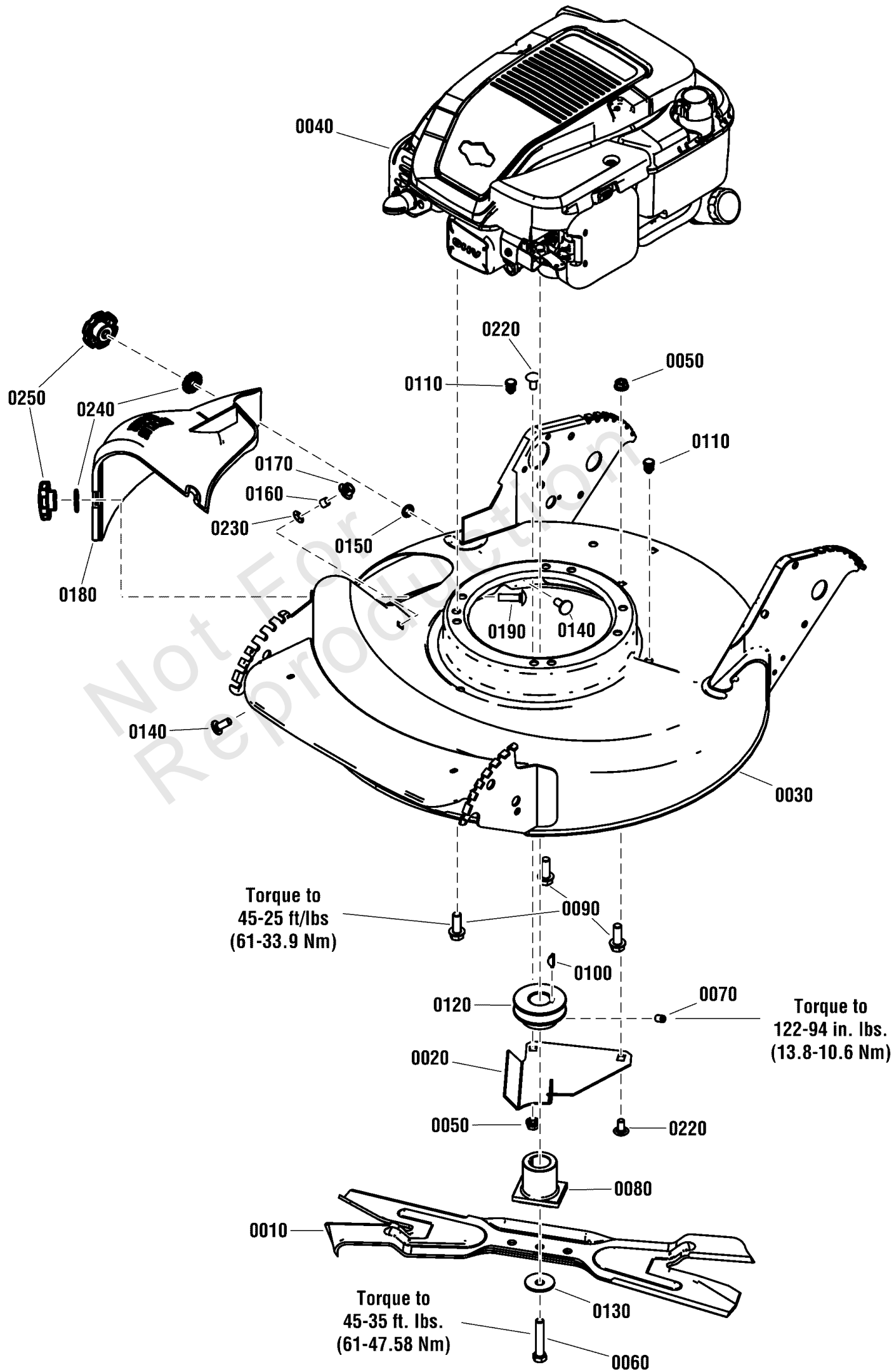

Deck, Engine & Blade Group

REF NO	PART NO	QTY	DESCRIPTION
0010	7026407AYP	1	BLADE, 21" Ninja Mulching
0020	7074568YP	1	COVER, Belt, Zinc/Clear
0030	7400026DYP	1	WELDMENT, Deck, 21" AIR, Non-Adj.
0040	123P32-0065-F1	1	* ENGINE, B&S PRO, 8.5TP, 123P32-0065-F1
0050	703409	2	NUT, 5/16-18, GR5
0060	703999	1	SCREW, 3/8-24 x 2" Hex Head Cap, GR 5
0070	704003	1	SET SCREW, 5/16-18 x 1/2" Hex Recess
0080	7101414YP	1	HUB, Blade, 21 WBM, 25MM ID, 2 Position
0090	704000	3	SCREW, Hex Washer Head, Taptite, 3/8-16 x 1
0100	703891	1	KEY, 3/16X.625
0110	7046780SM	2	PLUG, Hole, .44" OD
0120	7105122YP	1	PULLEY, Engine (25mm I. D. x 2-1/8 O.D.)
0130	703963	1	WASHER, CONE
0140	703185	2	BOLT, Round Head, Short Square Neck
0150	703297	2	RETAINER, GR5, 5/16
0160	7024340SM	1	SPACER
0170	704001	1	NUT, 5/16-18
0180	7029149YP	1	COVER, Mulching, 21" Deck
0190	704002	1	BOLT, 5/16-18X1.125
0220	703447	2	BOLT, 5/16-18X.625 G5
0230	7101022YP	2	KNOB, Fluted
0240	703936	2	WASHER, .325IDX.850OD

Footnotes:

NOTE: * Purchase engine & engine parts from engine service outlets.

Drive System, Self Propelled

Note: Unless noted otherwise, use the standard torque specifications

Mfg. No: 7800968B-00

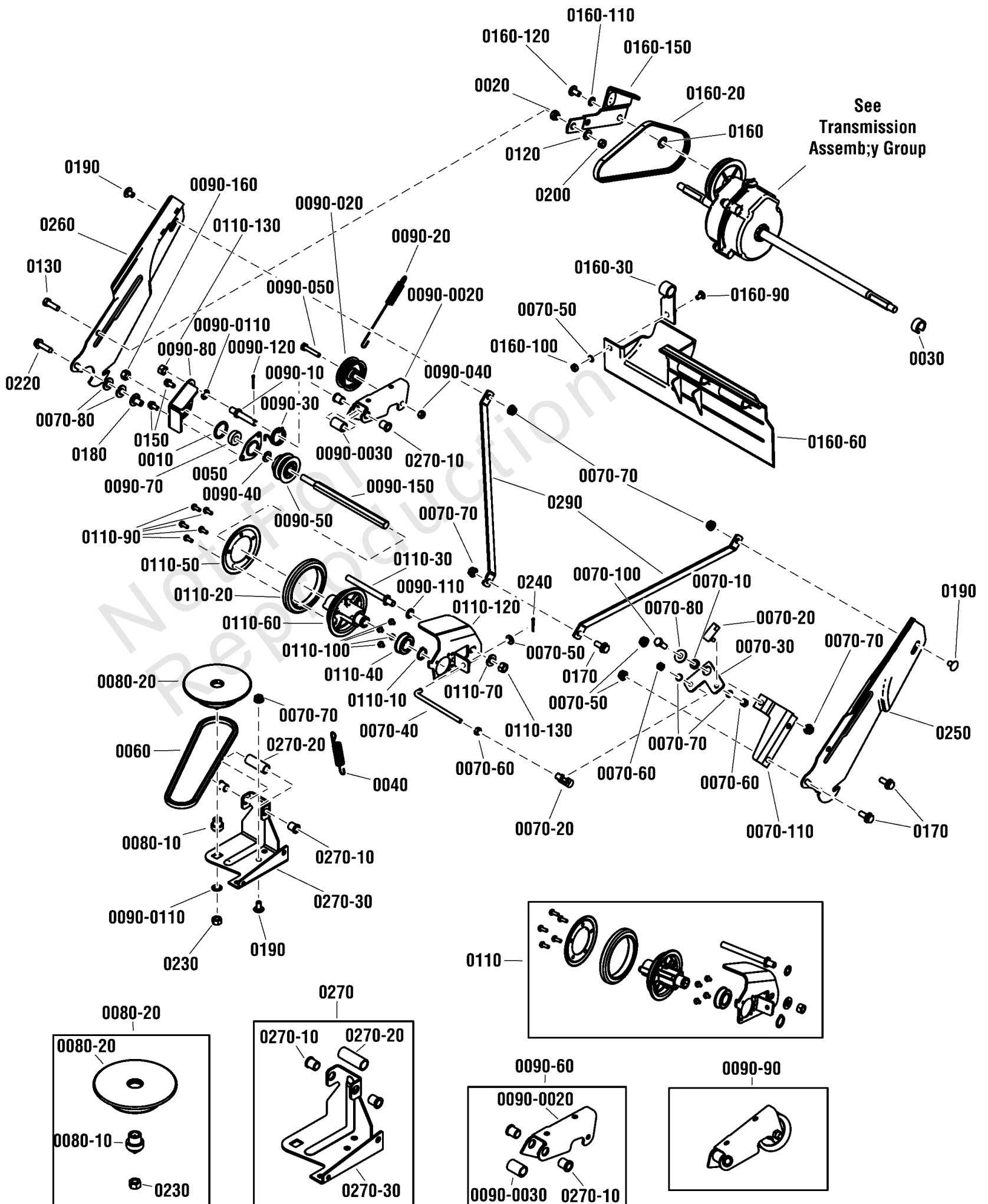

Drive System, Self Propelled

REF NO	PART NO	QTY	DESCRIPTION
0010	704008	1	O-RING, 1IDX1.25X.125
0020	7012114SM	1	BUSHING, Differential Link
0030	704009	1	RING, .68IDX.93X.44
0040	7029025YP	1	SPRING, Extension, .58 x 3.2
0050	7031809YP	1	HOLDER, Bearing (Outer Half), ZC/CL
0060	7046784YP	1	BELT, Engine Drive (Stretch)
0070-10	703970	1	SPACER
0070-20	7015753YP	2	BALL JOINT, 1/4-28
0070-30	7073913YP	1	BELL CRANK, Black Zinc
0070-40	7074145YP	1	LINK, Transfer (1/4-28 thread)
0070-50	703462	3	WASHER, LOCK, 1/4
0070-60	703461	3	NUT, 1/4-28 Hex, GR5, Zinc/Clear
0070-70	703409	7	NUT, 5/16-18, GR5
0070-80	7900022YP	3	FW, YZ
0070-100	703408	1	CAPSCREW, 5/16-18
0070-110	7073822BMYP	1	BRACKET, Bell Crank
0080	7061275YP		KIT, Drive Disc, Steel (includes Disc, Bushing & Nut)
0080-10	703971	1	BUSHING
0080-20	7073528YP	1	DRIVE DISC, Steel (Includes Bushing)
0090-10	703836	1	STUD, 3/8-24X2.380
0090-20	7012122YP	1	SPRING, Clutch, Adjustable Tension
0090-30	7012126YP	1	SPRING, Idler Torsion
0090-40	703946	1	WASHER, .39IDX.72OD
0090-50	7019383YP	1	PULLEY, Poly-V, 2" OD, .65" Wide, Steel
0090-70	7028014YP	1	BALL BEARING, Spherical O.D., .38 I.D.
0090-80	7031873YP	1	HOLDER, Bearing (Inner Half)
0090-90	7051921YP	1	ASSEMBLY, Clutch Idler (Pulley, Nut, Bolt, Bushings & Spacer)
0090-020	7012124YP	1	PULLEY, Flat Idler, .25 ID, 2.25 OD
0090-040	703972	1	NUT, HEX TOP, 1/4-28
0090-050	703828	1	CAPSCREW, 1/4-28X1.75
0090-060	7600173YP	1	KIT, Idler Arm, Bushing & Spacer Assembly
0090-0020	7032832AYP	1	ARM, CLUTCH IDLER
0090-0030	703974	1	SPACER, Idler Arm (.500 ID x .970 Long), ZC/CL
0090-110	703930	3	WASHER, INT LCK, 3/8
0090-120	703312	1	PIN, COTTER, 3/32X.75
0090-150	7072284YP	1	SHAFT, Hex (3/8-24 thread, one end)
0090-160	703458	1	NUT, HEX, 3/8-24
0110	7600109YP	1	KIT, DRIVEN DISC ASSY
0110-10	703975	1	RETAINER, RING, 3/4
0110-20	704059	1	RING, 3IDX4ODX.56THK
0110-30	703837	1	STUD, 3/8-24X4.5
0110-40	7029027YP	1	BEARING, 3/4" ID, Ball, Commercial
0110-50	7031013YP	1	PLATE, Driven Tire Side
0110-60	7061276YP	1	HUB / DRIVEN DISC KIT
0110-70	703590	1	WASHER, FLAT, .406
0110-90	704060	7	SCREW,HEX, #10-24X.5
0110-100	704061	4	SCREW,HEX, #10-32X.25
0110-120	7300977BMYP	1	THRUST PLATE, Short, Black
0110-130	703895	2	NUT, HEX, 3/8-24
0120	703350	1	WASHER
0130	MT910828MA	1	BOLT,5/16-24 X 1.00,HEX,ZC/CL

Drive System, Self Propelled

Note: Unless noted otherwise, use the standard torque specifications

Mfg. No: 7800968B-00

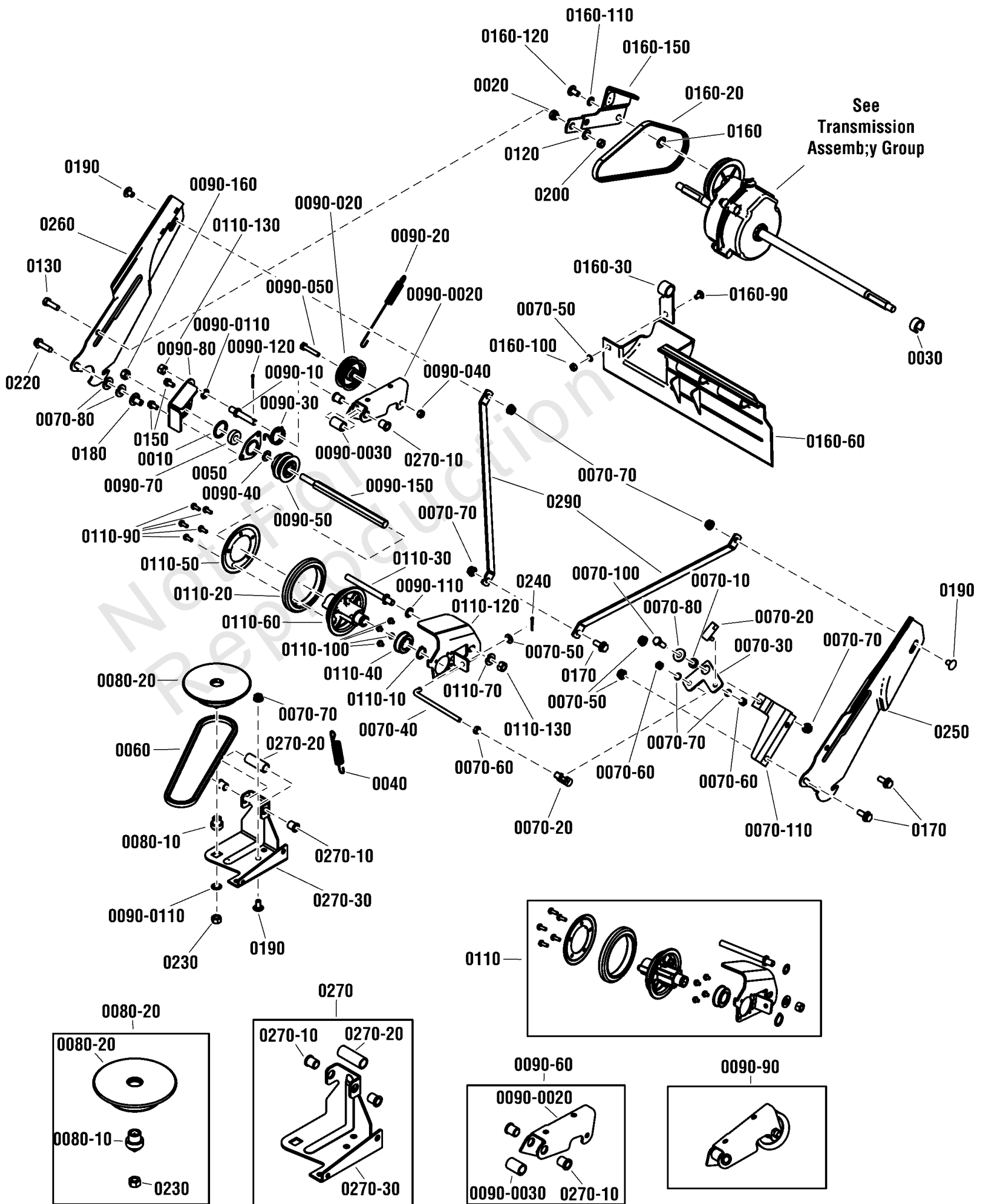

Drive System, Self Propelled

REF NO	PART NO	QTY	DESCRIPTION
0150	704130	2	SCREW, HEX, 1/4-20X.5
0160	703940	1	WASHER, .445IDX.78OD
0160-20	7012354YP	1	BELT, Poly-V, Kevlar, V21
0160-30	7012616YP	1	SUPPORT, Foot Guard
0160-60	7029008YP	1	GUARD, Foot, P21 EURO, Long
0160-90	703978	1	BOLT, 1/4-20X0.5
0160-100	703127	1	NUT
0160-110	7090391SM	1	WASHER, Internal Tooth, 5/16
0160-120	1753983YP	1	SCREW, Truss Head
0160-150	7034179BMYP	1	LINK, DIFFERENTIAL
0170	703354	3	SCREW, 5/16-18
0180	703947	1	NUT, 5/16-18 X .625, Weld, ZC/CL
0190	703447	1	BOLT, 5/16-18X.625 G5
0200	703896	1	NUT, HEX, 5/16-24
0220	703167	1	SCREW
0230	703457	1	NUT, HEX, 3/8-16, GR5
0240	1501125MA	1	GEAR, 9 Tooth
0250	7033985AYP	1	HANDLE, Lower, ADJ, LH
0260	7033986AYP	1	HANDLE, LOWER, RH
0270	7052987BMYP	1	ASSEMBLY, Deck Bracket, P21S
0270-10	703973	4	BUSHING
0270-20	703941	1	SPACER, .51DX.64OD
0270-30	7033774YP	1	BRKT, DECK, P21S
0290	7046707BMYP	2	BRACE, HANDLE ECOAT

Handle Group

Note: Unless noted otherwise, use the standard torque specifications

Mfg. No: 7800968B-00

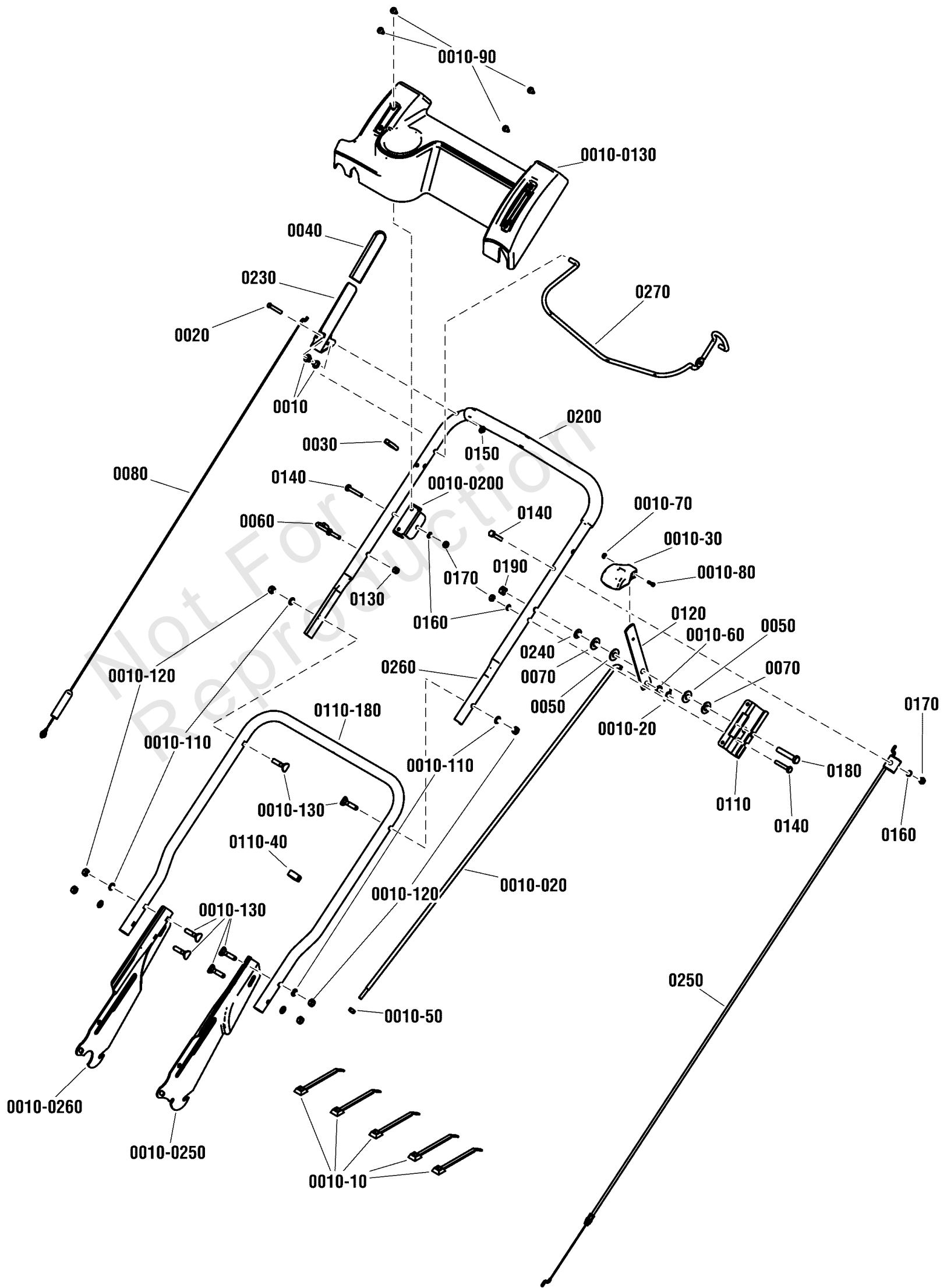

Handle Group

REF NO	PART NO	QTY	DESCRIPTION
0010	7014343YP	2	BUSHING, Flanged, .27 ID, Nylon, Black
0010-10	7024641YP	5	WIRE TIE, 5.5" L
0010-20	704030	1	PIN,COTTER,5/16X1.044
0010-30	7075182YP	1	KNOB, Shift, Red
0010-50	703461	1	NUT, 1/4-28 Hex, GR5, Zinc/Clear
0010-60	703350	1	WASHER
0010-70	703460	1	NUT, Hex #8-32
0010-80	703351	1	SCREW, #8-32 X 0.50, Machine Fillister Head, Zinc/Clear
0010-90	703961	4	SCREW, 1/4-20 X .550, T-30 Pan Head Torx, Self-Tap
0010-110	7090391SM	6	WASHER, 5/16, Internal Lock, Zinc/Clear
0010-120	703465	6	NUT, 5/16-18, GRB, Zinc/Clear
0010-130	704063	6	BOLT,HEX,5/16-18X1.5
0010-020	7074133YP	1	ROD, Speed Control (35.5" L, 1/4-28 thread)
0010-0130	7106275YP	1	PANEL, Dash, ES W/O Throttle
0010-0200	7106274BMYP	1	BRACKET, Panel Mount, Black
0010-0250	7033985AYP	1	HANDLE, Lower, ADJ, LH
0010-0260	7033986AYP	1	HANDLE, LOWER, RH
0020	704031	1	PIN, CLEVIS, 1/4X1.5
0030	7026219YP	1	CLAMP, 7/8" Double Cable
0040	7028407YP	1	GRIP, International Symbol, 4.6" Black
0050	704004	2	WASHER,.406IDX1OD
0060	7028488MA	1	GUIDE, 1/4-20, Rope, CL/ZC
0070	703964	2	WASHER, FLAT
0080	7034604YP	1	CABLE, Clutch Control, 41.25" L
0110	7074003YP	1	BRACKET, Shift, Black Zinc
0110-40	7023813SM	1	CLIP, Wiring Harness
0110-180	7106232AYP	1	HANDLE, Middle, Black
0120	7074113YP	1	LEVER, Shift
0130	703232	1	NUT, 1/4-20, NYLOCK
0140	703234	3	CAPSCREW, 1/4-20X1.5
0150	704005	1	PUSHNUT, CAP, 1/4
0160	703462	3	WASHER, LOCK, 1/4
0170	703127	3	NUT
0180	703589	1	CAPSCREW, 3/8-16X2
0190	703347	1	NUT, 3/8-16
0200	7023810YP	1	FOAM GRIP, 18.75"
0230	7074473BMYP	1	HANDLE, CLUTCH
0240	704006	1	WASHER, .393IDX.760OD
0250	7106257YP	1	CABLE, OPC, 50.56" Long, Z Ends, Snap-in, for Over-the-Top Bail
0260	7106258AYP	1	HANDLE
0270	7106255AYP	1	BAIL,OPC,Over-the-Top, Black

Transmission Assembly

Note: Unless noted otherwise, use the standard torque specifications

Mfg. No: 7800968B-00

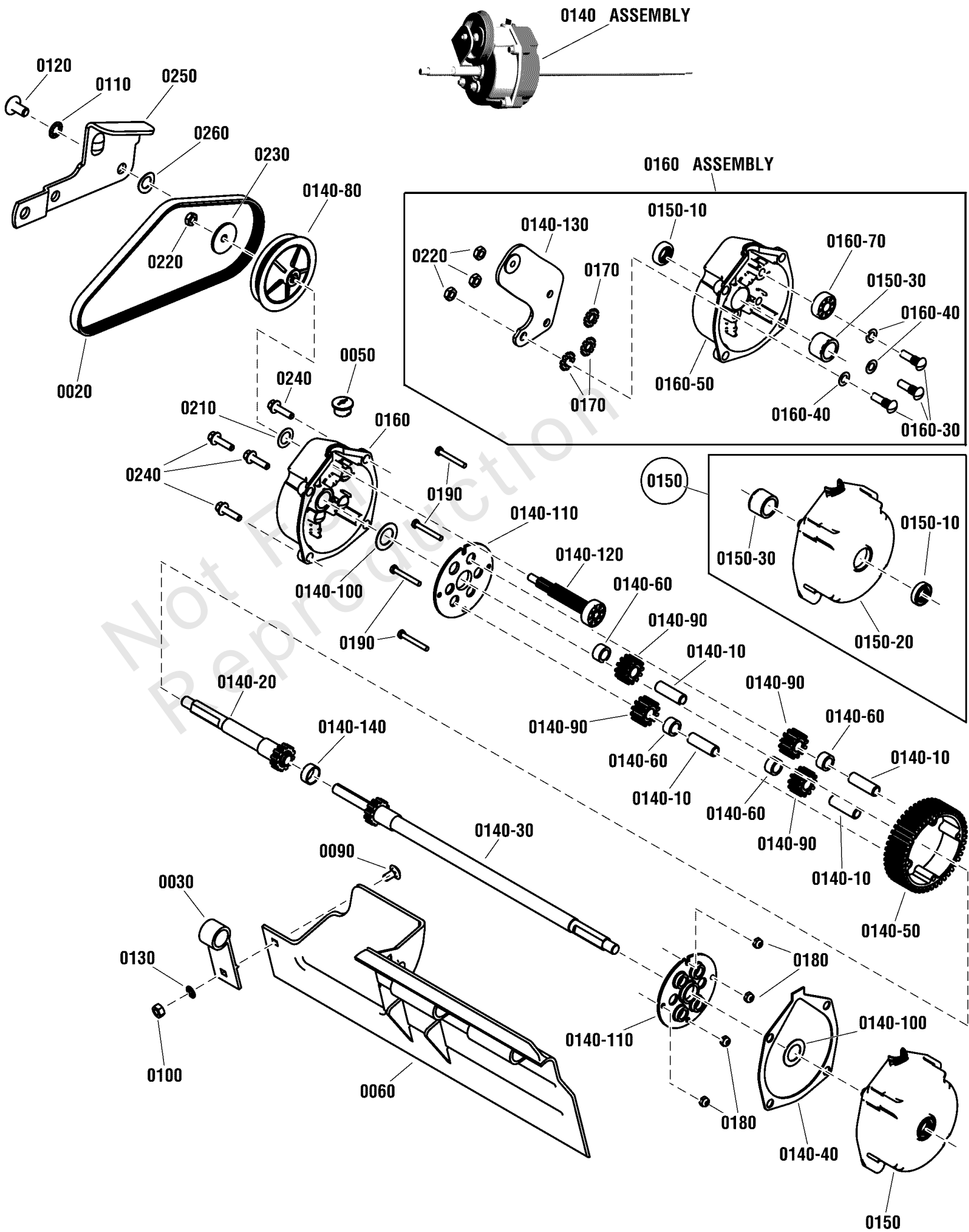

Transmission Assembly

REF NO	PART NO	QTY	DESCRIPTION
0020	7012354YP	1	BELT, Poly-V, V21
0030	7012616YP	1	SUPPORT, Foot Guard
0040	-----		GREASE, Darina 00 (Not Shown, Use 4oz. Max)
0050	703931	1	PLUG, TRANSMISSION
0060	7029008YP	1	GUARD, Foot
0090	703978	1	BOLT, 1/4-20X0.5
0100	703127	1	NUT
0110	7090391SM	1	WASHER, 5/16, Internal Lock, Zinc/Clear
0120	1753983YP	1	SCREW, 5/16-18 x 5/8 Truss Head Torx
0130	703462	1	WASHER, LOCK, 1/4
0140	7053943YP	1	ASSEMBLY, Transmission, 21P
0140-10	7011110YP	4	SHAFT, Pinion, .471 OD, 1.5" Long
0140-40	7011774YP	1	GASKET, V21
0140-50	7012495YP	1	GEAR, 46T, V21
0140-60	703933	4	SPACER, .48IDX.70OD
0140-80	7019213YP	1	PULLEY, Poly-V (3.5 O.D.)
0140-90	7021115YP	4	GEAR, Pinion (12 Tooth, .625 Thick)
0140-100	7031965YP	2	WASHER, 1.25 X .765 X .03, Thrust, ZC/CL
0140-110	7031970YP	2	PLATE, Differential Gear, V21
0140-120	7050767YP	1	ASSEMBLY, Input Gear
0140-130	7051903AYP	1	WELDMENT, Differential Bracket
0140-140	703934	1	SPACER, .72IDX.82OD
0140-20	7050830YP	1	ASSEMBLY, Short Axle
0140-30	7050831YP	1	ASSEMBLY, Long Axle
0150	7053939YP	1	ASSEMBLY, Left Housing
0150-10	7012314YP	2	SEAL, 5/8" ID
0150-20	7029033YP	1	HOUSING, Left Hand
0150-30	7029035YP	2	BEARING, Tapered, Differential Housing
0160	7051908YP	1	ASSEMBLY, Housing, Right Hand
0160-30	703935	3	BOLT, 5/16-24X1.125
0160-40	7024442YP	3	GASKET, 5/8" O.D.
0160-50	7029034YP	1	HOUSING, Right Hand
0160-70	7073963YP	1	BEARING, Ball, 1.125 OD, .440 ID, 3.8 Wide
0170	703936	3	WASHER, .325IDX.850OD
0180	703937	4	NUT, NYLOCK, 10-32
0190	703938	4	CAPSCREW, 10-32X1.5
0210	703349	1	WSHR, 0.453
0220	703459	4	NUT, HEX, 5/16-24
0230	703939	1	WASHER, .32IDX1.4OD
0240	703833	4	SCREW, 1/4-20 x 1 Hex Washer Self-Tap, ZC/CL
0250	7034179BMYP	1	LINK, DIFFERENTIAL
0260	703940	1	WASHER, .445IDX.78OD

Wheels, Brackets & Latches

Note: Unless noted otherwise, use the standard torque specifications

Mfg. No: 7800968B-00

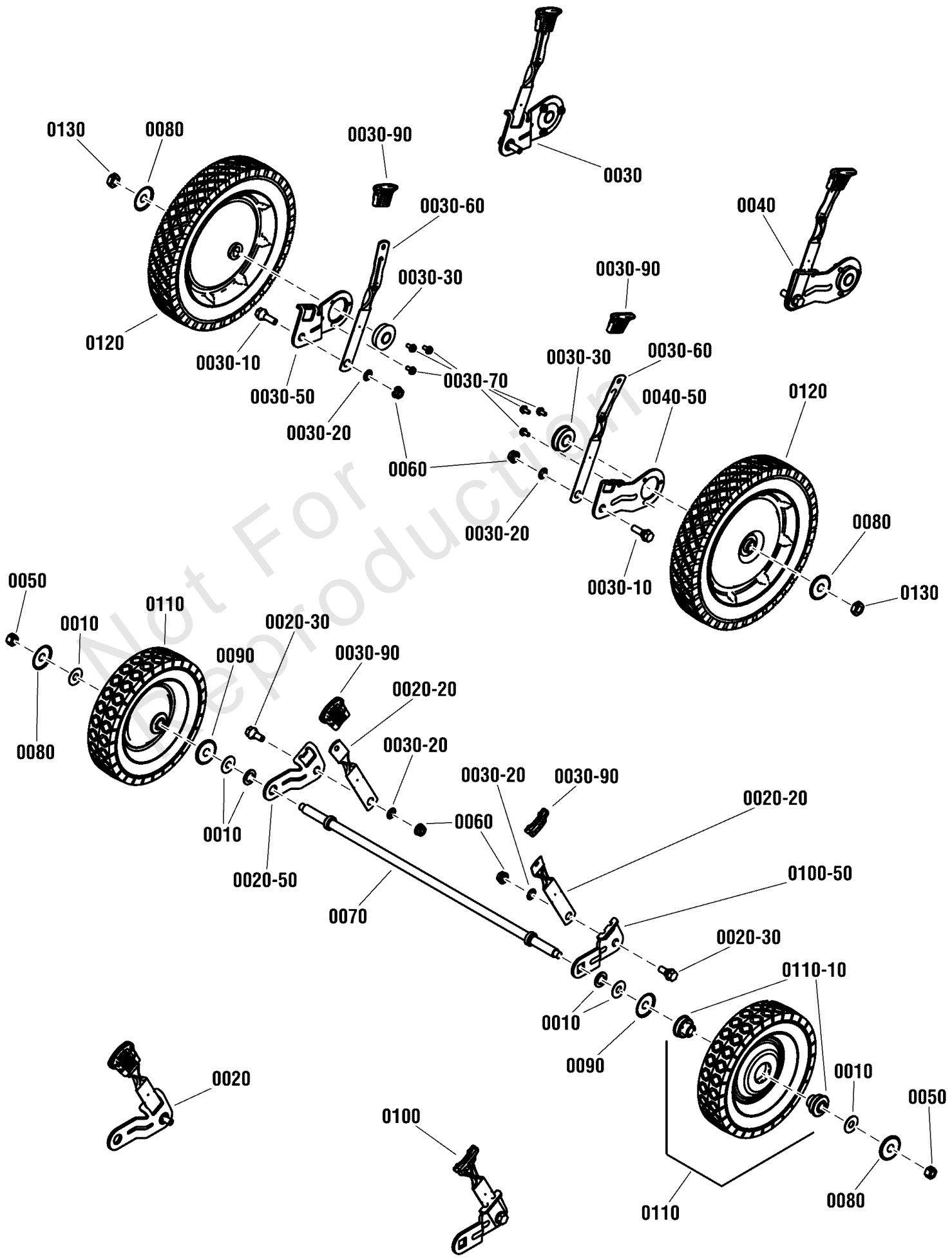

Wheels, Brackets & Latches

REF NO	PART NO	QTY	DESCRIPTION
0010	703964	6	WASHER, FLAT
0020	7600180YP	1	KIT, FRONT WHEEL ARM
0020-20	7012325YP	2	LATCH, Height
0020-30	703839	2	BOLT, 5/16-18X.75
0020-50	7031017YP	1	WHEEL ARM, Front, Round Hole, RH, Clear
0030	7054246YP	1	WHEEL ARM ASMY, RR
0030-10	703840	2	BOLT,SHLDR 5/16-18X1
0030-20	703297	4	RETAINER, GR5, 5/16
0030-30	7012312YP	2	BEARING, 9/16" ID
0030-50	7032722YP	1	WHEEL ARM, REAR RH
0030-60	7035717YP	2	LATCH, Height Adjusting, (long)
0030-70	703967	6	SCREW, #10-32X0.375
0030-90	7103793YP	4	GRIP, HT LATCH, BLACK
0040	7054247YP	1	WHEEL ARM ASMY, LR
0040-50	7032723YP	1	ARM, Wheel, Left Rear, Zinc/Clear
0050	703348	2	NUT,7/16-20
0060	703409	4	NUT, 5/16-18, GR5
0070	7021119YP	1	AXLE, V21
0080	7031960YP	4	HUBCAP
0090	7031121YP	2	HUBCAP, V21
0100	7600179YP	1	KIT, FRONT WHEEL ARM
0100-50	7031016YP	1	WHEEL ARM, L.H. Front (Square Hole)
0110	7035727YP	2	WHEEL, 8 x 1.75 - Steel - D - Gray
0110-10	7011125YP	4	BEARING, 7/16" ID, Ball, Front Wheel
0120	7035726YP	2	WHEEL,(SP)-GRAY
0130	770537	2	NUT, 7/16-20, Hex Flanged Center Lock, ZC/CL

Hardware Identification & Torque Specifications

Torque Specification Chart								
FOR STANDARD METRIC MACHINE HARDWARE (Tolerance ± 20%)								
Property Class	5.6		8.8		10.9		12.9	
	Class 5.6		Class 8.8		Class 10.9		Class 12.9	
Size Of Hardware	in/lbs	Nm.	in/lbs	Nm.	in/lbs	Nm.	in/lbs	Nm.
	ft/lbs		ft/lbs		ft/lbs		ft/lbs	
M3	5.88	.56	13.44	1.28	19.2	1.80	22.92	2.15
M4	13.44	1.28	30.72	2.90	43.44	4.10	52.56	4.95
M5	26.4	2.50	60.96	5.75	5.97	8.10	7.15	9.7
M6	44.64	4.3	7.3	9.9	10.3	14	12.1	16.5
M7	5.2	7.1	12.1	16.5	16.9	23	19.9	27
M8	7.7	10.5	17.7	24	25	34	29	40
M10	15	21	35	48	50	67	59	81
M12	26	36	61	83	86.2	117	103	140
M14	42	58	101	132	136	185	162	220
M16	64	88	147	200	210	285	250	340
M18	89	121	202	275	287	390	346	470
M20	126	171	290	390	405	550	486	660
M22	169	230	390	530	559	745	656	890
M24	217	295	497	375	708	960	840	1140
M27	320	435	733	995	1032	1400	1239	1680
M30	435	590	995	1350	1401	1900	1681	2280
M33	590	800	1349	1830	1902	2580	2278	3090
M36	759	1030	1740	2360	2441	3310	2935	3980
M39	988	1340	2249	3050	3163	4290	3798	5150

Torque Specification Chart						
FOR STANDARD MACHINE HARDWARE (Tolerance ± 20%)						
Hardware Grade	No Marks		SAE Grade 5		SAE Grade 8	
	SAE Grade 2		SAE Grade 5		SAE Grade 8	
Size Of Hardware	in/lbs	Nm.	in/lbs	Nm.	in/lbs	Nm.
	ft/lbs		ft/lbs		ft/lbs	
8-32	19	2.1	30	3.4	41	4.6
8-36	20	2.3	31	3.5	43	4.9
10-24	27	3.1	43	4.9	60	6.8
10-32	31	3.5	49	5.5	68	7.7
1/4-20	66	7.6	8	10.9	12	16.3
1/4-28	76	8.6	10	13.6	14	19.0
5/16-18	11	15.0	17	23.1	25	34.0
5/16-24	12	16.3	19	25.8	29	34.0
3/8-16	20	27.2	30	40.8	45	61.2
3/8-24	23	31.3	35	47.6	50	68.0
7/16-14	30	40.8	50	68.0	70	95.2
7/16-20	35	47.6	55	74.8	80	108.8
1/2-13	50	68.0	75	102.0	110	149.6
1/2-20	55	74.8	90	122.4	120	163.2
9/16-12	65	88.4	110	149.6	150	204.0
9/16-18	75	102.0	120	163.2	170	231.2
5/8-11	90	122.4	150	204.0	220	299.2
5/8-18	100	136	180	244.8	240	326.4
3/4-10	160	217.6	260	353.6	386	525.0
3/4-16	180	244.8	300	408.0	420	571.2
7/8-9	140	190.4	400	544.0	600	816.0
7/8-14	155	210.8	440	598.4	660	897.6
1-8	220	299.2	580	788.8	900	1,244.0
1-12	240	326.4	640	870.4	1,000	1,360.0

The guides and ruler furnished below are designed to help you select the appropriate hardware.



Nut, M8

Thread Diameter (mm)

Inside Diameter (in) Threads per inch

Nut, 1/2-16

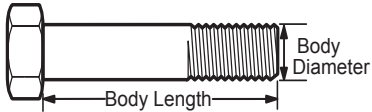

Screw, M8- 1.25 x 25

Thread Diameter (mm) Distance between threads (mm) Body Length (mm)

Body Diameter Threads per inch Body Length (in)

Screw, 1/2- 16 x 2

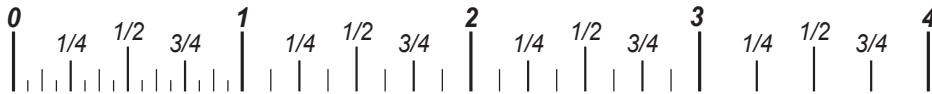

Standard Hardware Sizing

When a washer or nut is identified as 1/2" (M8), this is the *Nominal size*, meaning the *inside diameter* is 1/2 inch (8mm metric thread diameter); if a second number is present it represents the *threads per inch* (distance between threads).

When bolt or capscrew is identified as 1/2 - 16 x 2" (M8 - 1.25 x 50), this means the *Nominal size*, or body diameter is 1/2 inch (8mm metric thread diameter), the second number, 16, represents the *threads per inch*, (*distance between threads*). The final number is the body length of the bolt or screw, 2 inches (50mm).

NOTES

- These torque values are to be used for all hardware excluding: locknuts, self-tapping screws, thread forming screws, sheet metal screws and socket head setscrews.
- Recommended seating torque values for locknuts:
 - for prevailing torque locknuts - use 65% of grade 5 torques.
 - for flange whizlock nuts and screws - use 135% of grade 5 torques.
- Unless otherwise noted on assembly drawings, all torque values must meet this specification.

Common Hardware Types

Hex Head Capscrew

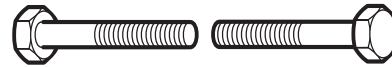

Washer



Carriage Bolt



Hex Nut

Wrench & Fastener Size Guide

1/4" Bolt or Nut Wrench—7/16"	5/16" Bolt or Nut Wrench—1/2"	3/8" Bolt or Nut Wrench—9/16"	7/16" Bolt or Nut Wrench (Bolt)—5/8" Wrench (Nut)—11/16"	1/2" Bolt or Nut Wrench—3/4"
M6 Bolt or Nut Wrench—10mm	M8 Bolt or Nut Wrench—13mm	M10 Bolt or Nut Wrench—17mm	M12 Bolt or Nut Wrench—19mm	M14 Bolt or Nut Wrench—22mm

